

# Condensers

**C11HI – C45HI**

**11 - 45 kW**

**CS50 – CS105**

**50 – 105kW**



# TECHNICAL MANUAL



FM00542

EMS52086

## About Airedale Products & Customer Services

### WARRANTY, COMMISSIONING & MAINTENANCE

As standard, Airedale guarantees all non consumable **parts only** for a period of **12 months**, variations tailored to suit product and application are also available; please contact Airedale for full terms and details.

To further protect your investment in Airedale products, we have introduced Airedale Service, who can provide full commissioning services, comprehensive maintenance packages and service cover 24 hours a day, 365 days a year (UK mainland). For a free quotation contact our Airedale Service or your local Sales Engineer.

All Airedale products are designed in accordance with EU Directives regarding prevention of build up of water, associated with the risk of contaminants such as Legionella.

Where applicable, effective removal of condensate is achieved by gradient drainage to outlets and where used, humidification systems produce sterile, non-toxic steam during normal operation.

For effective prevention of such risk it is necessary that the equipment is maintained in accordance with Airedale recommendations.

### CAUTION

**Warranty cover is not a substitute for maintenance. Warranty cover is conditional to maintenance being carried out in accordance with the recommendations provided during the warranty period. Failure to have the maintenance procedures carried out will invalidate the warranty and any liabilities by Airedale International Air Conditioning Ltd.**

### SPARES

A spares list for 1, 3 and 5 years will be supplied with every unit and is also available from our Spares department on request.

### TRAINING

As well as our comprehensive range of products, Airedale offers a modular range of Refrigeration and Air Conditioning Training courses, for further information please contact Airedale.

### CUSTOMER SERVICES

For further assistance, please e-mail: [enquiries@airedale.com](mailto:enquiries@airedale.com) or telephone:

<b>UK Sales Enquiries</b>	+ 44 (0) 113 238 7789	<a href="mailto:enquiries@airedale.com">enquiries@airedale.com</a>
<b>International Enquiries</b>	+ 44 (0) 113 239 1000	<a href="mailto:enquiries@airedale.com">enquiries@airedale.com</a>
<b>Spares Hot Line</b>	+ 44 (0) 113 238 7878	<a href="mailto:spares@airedale.com">spares@airedale.com</a>
<b>Airedale Service</b>	+ 44 (0) 113 239 1000	<a href="mailto:service@airedale.com">service@airedale.com</a>
<b>Technical Support</b>	+ 44 (0) 113 239 1000	<a href="mailto:tech.support@airedale.com">tech.support@airedale.com</a>
<b>Training Enquiries</b>	+ 44 (0) 113 239 1000	<a href="mailto:marketing@airedale.com">marketing@airedale.com</a>

For information, visit us at our Web Site: [www.airedale.com](http://www.airedale.com)

AIAC Ltd endeavours to ensure that the information in this document is correct and fairly stated, but none of the statements are to be relied upon as a statement or representation of fact. AIAC Ltd does not accept liability for any error or omission, or for any reliance placed on the information contained in this document.

The development of Airedale products and services is continuous and the information in this document may not be up to date. It is important to check the current position with AIAC Ltd at the address stated. This document is not part of a contract or licence unless expressly agreed.

No part of this document may be reproduced or transmitted in any form or by any means, electronic or mechanical, including photocopying, recording, or information storage and retrieval systems, for any purpose other than the purchaser's personal use, without the express written permission of AIAC Ltd.

© 2018 Airedale International Air Conditioning Limited. All rights reserved. Printed in the UK.

## Warranty

All AIAC products or parts (non consumable) supplied for installation within the UK mainland and commissioned by an AIAC engineer, carry a full Parts & Labour warranty for a period of 12 months from the date of commissioning or 18 months from the date of despatch, whichever is the sooner.

Parts or Equipment supplied by AIAC for installation within the UK or for Export that are properly commissioned in accordance with AIAC standards and specification, not commissioned by an AIAC engineer; carry a 12 month warranty on non consumable Parts only from the date of commissioning or 18 months from the date of despatch, whichever is the sooner.

Parts or equipment installed or commissioned not to acceptable AIAC standards or specification invalidate all warranty.

## Warranty is only valid in the event that

In the period between delivery and commissioning the equipment: is properly protected & serviced as per the AIAC installation & maintenance manual provided where applicable the glycol content is maintained to the correct level.

In the event of a problem being reported and once warranty is confirmed as valid under the given installation and operating conditions, the Company will provide the appropriate warranty coverage (as detailed above) attributable to the rectification of any affected Airedale equipment supplied (excluding costs for any specialist access or lifting equipment that must be ordered by the customer).

Any spare part supplied by Airedale under warranty shall be warranted for the unexpired period of the warranty or 3 months from delivery, whichever period is the longer.

To be read in conjunction with the Airedale Conditions of Sale - Warranty and Warranty Procedure, available upon request.

## Procedure

When a component part fails, a replacement part should be obtained through our Spares department. If the part is considered to be under warranty, the following details are required to process this requirement.

Full description of part required, including Airedale's part number, if known

The original equipment serial number

An appropriate purchase order number

A spares order will be raised under our warranty system and the replacement part will be despatched, usually within 24 hours should they be in stock.

When replaced, the faulty part must be returned to Airedale with a suitably completed and securely attached "Faulty Component Return" (FCR) tag. FCR tags are available from Airedale and supplied with each Warranty order.

On receipt of the faulty part, suitably tagged, Airedale will pass to its Warranty department, where it will be fully inspected and tested in order to identify the reason for failure, identifying at the same time whether warranty is justified or not.

On completion of the investigation of the returned part, a full "Report on Goods Returned" will be issued. On occasion the release of this complete report may be delayed as component manufacturers become involved in the investigation.

When warranty is allowed, a credit against the Warranty invoice will be raised. Should warranty be refused the Warranty invoice becomes payable on normal terms.

## Exclusions

Warranty may be refused for the following reasons:

- Misapplication of product or component
- Incorrect site installation
- Incomplete commissioning documentation
- Inadequate site installation
- Inadequate site maintenance
- Damage caused by mishandling
- Replaced part being returned damaged without explanation
- Unnecessary delays incurred in return of defective component

## Returns analysis

All faulty components returned under warranty are analysed on a monthly basis as a means of verifying component and product reliability as well as supplier performance. It is important that all component failures are reported correctly.

---

## Contents

<b>General Description</b>	<b>5</b>
Unit Identification	5
Introduction	5
Standard Features	6
Optional Extras	7
<b>General Specification</b>	<b>8</b>
Mechanical Data	8
Electrical Data	10
Interconnecting Wiring	10
<b>Performance Data</b>	<b>11</b>
Capacity Data	11
Operating Limits	11
<b>Sound Data</b>	<b>12</b>
Method of Sound Measurement	12
Sound Data	12
<b>Dimensional &amp; Installation Data</b>	<b>13</b>
Dimensions / MASSES / Positioning - Horizontal	13
Dimensions / MASSES / Positioning - Vertical	14
Unit Lifting	17
Siting Recommendations	17

## General Description

### UNIT IDENTIFICATION

AIR COOLED CONDENSER UNIT	
<b>C / CS</b>	Condenser
<b>11-105</b>	Model Size (Expressed as Total Heat Rejection in kW)
<b>HI</b>	Head Pressure Control & Mains Isolator Fitted (C Condensers only)
<b>H</b>	Horizontal Air Discharge
<b>V</b>	Vertical Air Discharge
<b>Example:</b>	<b>C45HI-H</b> <b>CS50H-0</b>

### INTRODUCTION

This range of Air Cooled Condensers is available in 10 model sizes with heat of rejection 11 - 105kW.

Custom designed for a small footprint, low sound level, slimline and aesthetically pleasing appearance.

Available in either horizontal or vertical air discharge orientation, *please specify at order.*

Airedale has a comprehensive range of air cooled direct expansion indoor units available to provide a matched system, please contact Airedale for further details.

All units are despatched following extensive leak and pressure testing and carry a holding charge of inert gas.

The unit is designed for the use of R407C; please refer to **Optional Extras** for alternative refrigerants.

### CE Directive



Airedale certify that the equipment detailed in this manual conforms with the following EC Directives:

Electromagnetic Compatibility Directive (EMC)	<b>2014/30/EU</b>
Machinery Directive (MD)	<b>89/392/EEC in the version</b> <b>2006/42/EC</b>
Pressure Equipment Directive (PED)	<b>2014/68/EU</b>

To comply with these directives appropriate national & harmonised standards have been applied. These are listed on the Declaration of Conformity, supplied with each product.

#### Refrigeration

Allowable Temperature Range (TS) = Min -20°C\* to Max 120°C\*\*

Maximum Allowable Pressure (PS) = High Side 40.7 Barg , Low Side N/A Barg

\*Based on the refrigerant temperature in the unit off state in the lowest permitted ambient temperature.

\*\*Based on the maximum allowable super-heated refrigerant temperature.

## General Description

### STANDARD FEATURES

<b>Construction</b>	<p>Unit cabinets are manufactured from galvanised sheet steel coated with epoxy baked powder paint to provide a durable finish.</p> <p>Standard unit colour is Light Grey (RAL 7035).</p>
<b>Condenser</b>	<p>Large surface area coil(s) ideally positioned to optimise airflow and heat transfer, manufactured from refrigeration quality copper tube with mechanically bonded aluminium fins.</p> <p>The copper tube is internally rifled for improved heat transfer.</p> <p>Factory pressure tested to 40Bar.</p> <p>Sweat copper pipe for brazed connection as standard.</p>
<b>Fan &amp; Motor Assembly</b>	<p>Axial flow fan assembly with low noise sickle type blades and inlet ring.</p> <p>The external rotor motor allows the use of a low power output, single phase, speed controllable motor to power the fan.</p> <p>The motor has inbuilt thermal overload protection and the assembly is supplied complete with a finger guard for protection.</p>
<b>Refrigeration</b>	<p>Each unit features as standard:</p> <ul style="list-style-type: none"><li>• Filter drier (loose)</li><li>• Holding Charge of inert gas</li></ul>
<b>Electrical</b>	<p>All electrical components are rated for all year round outdoor use.</p> <p>All wiring is colour coded and numbered for identification. All units are wired in accordance with current local and European standards.</p>
<b>Head Pressure Control (C11 – 45)</b>	<p>Head pressure control is maintained via a factory fitted on/off pressure switch rated to IP54 for outdoor use as standard. This fan switching offers control with ambients down to 0°C, below this temperature variable speed controllers are recommended. Refer to <b>Optional Extras</b> for further information.</p>
<b>Head Pressure Control (CS50 – 105)</b>	<p>Head pressure control is maintained via a factory modulating head pressure control Good control with ambient down to 0°C.</p>
<b>Main Electric Isolator</b>	<p>A weatherproof mains isolator is fitted to ensure complete unit isolation of the electrical panel during adjustment and maintenance.</p>

## General Description

### OPTIONAL EXTRAS

**Corrosion Resistant Coated Coils** In atmospheres where high corrosion is anticipated, epoxy coated aluminium finned coils can be supplied.

**Head Pressure Control - Variable Speed** (Standard on CS50 - 105) Head pressure control is maintained via fan speed modulation. This is a more accurate form of control and will prolong the life of the fan. The controller is rated to IP54 for outdoor use and will operate accurately in ambients down to -20°C.

**Shut Off Valves** Where unit isolation for easier maintenance is required, shut off valves can be supplied loose for on site fitment.

**Short Case Axial Fans** Short case axial fans can be supplied for indoor installations where discharge air requires to be ducted to an outdoor location. The fans will meet duty plus 75Pa of external static pressure.

**Coil Guards** (Sizes 50 - 105 Only) Guards can be fitted to each of the outer coils to protect against damage.

**Electronically Commutated (EC) Fan Motor** (CS50-105 Only)



EC motors are DC motors with integrated AC to DC conversion; this gives the flexibility of connecting to AC mains with the efficiency and simple speed control of a DC motor. The EC fan offers significant power reduction in comparison with equivalent AC fan at both full and modulated fan speeds. The inbuilt EC fan control module allows for fan speed modulation from 15-100%, a standard ac fans modulating range is typically 40-100% of full fan speed.

The EC fan presents superior energy efficiency, at part load fan speeds compared to the equivalent ac fan motor, offering typical efficiency savings up to 70%.

Fan speeds are factory set to either 1080 rpm, 980 rpm or 700 rpm depending on sound level variant..

Standard voltage regulated (VR) fan speed controllers offer a linear response. By comparison the EC fan is adjusted on demand via the unit microprocessor with precision, offering substantial energy savings. The following illustration shows a comparison of the typical power input required by each method.

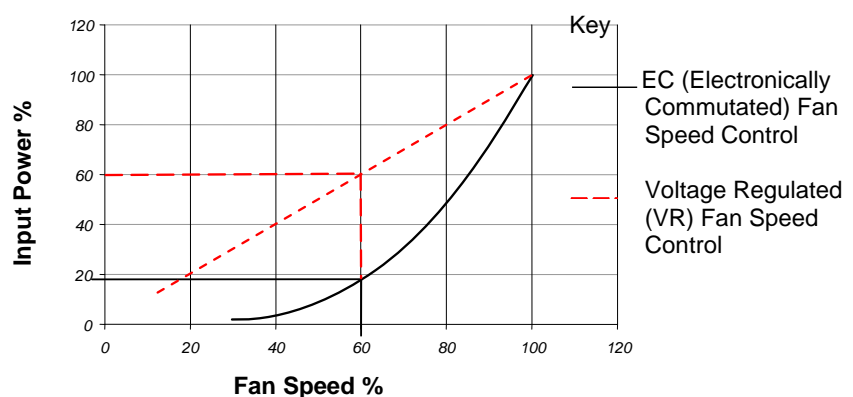

**Example:** Fan speed of 60%  
 VR input power required 60%  
 EC input power required 18%

## General Specification

## MECHANICAL DATA

		C11HI	C15HI	C20HI	C25HI	C35HI
<b>Total Heat of Rejection</b>	(1) kW	11	16.5	20.2	25.6	30.3
<b>Dimensions - Horizontal</b> (2)						
Height	mm	648	648	848	848	1048
Width	mm	550	550	645	645	645
Length	mm	1275	1275	1100	1100	1650
<b>Dimensions - Vertical</b> (2)						
Height	mm	997	997	1092	1092	1092
Width	mm	700	700	900	900	1100
Length	mm	1275	1275	1100	1100	1650
<b>Weight</b>						
Machine	kg	51	63	58	65	97
<b>Construction</b>						
Material/Colour		Galvanised Sheet Steel, Epoxy Baked Powder Paint - Light Grey (RAL 7035)				
<b>Condenser</b>		Air Cooled - Rifled Copper Tube/Turbulated Aluminium Fins				
Quantity		1	1	1	1	1
Total Face Area	m <sup>2</sup>	0.675	0.675	0.8	0.8	1.6
Nominal Airflow	m <sup>3</sup> /s	1.13	1.13	2.0	2.25	2.35
Discharge		<b>H</b> Horizontal or <b>V</b> Vertical ( <i>Please Specify at Order</i> )				
<b>Fan &amp; Motor</b>		Axial				
Quantity		1	2	1	1	1
Diameter	mm	450	450	630	630	630
Maximum Speed	rpm	1380	1380	900	900	900
<b>Refrigeration</b>		Single Circuit				
Refrigerant Type		R407C				
Holding Charge		Inert Gas				
Coil Volume	l	5.3	5.3	6.1	8.1	15.7
Refrigerant Charge	(3) kg	2.1	2.1	2.3	3.1	6.1
<b>Connections</b>						
Liquid Line - Sweat	in	1/2	1/2	5/8	5/8	7/8
Discharge Line - Sweat	in	5/8	5/8	7/8	7/8	7/8
<b>OPTIONAL EXTRAS</b>						
<b>Short Case Axial Fan</b>		Designed to 75 Pa ESP				
<b>Dimensions - Horizontal</b>						
Height	mm	648	648	848	848	1048
Width	mm	675	675	735	735	711
Length	mm	1275	1275	1100	1100	1650
<b>Dimensions - Vertical</b>						
Height	mm	1112	1112	1162	1162	1162
Width	mm	700	700	900	900	1100
Length	mm	1275	1275	1100	1100	1650
<b>Weight</b>						
Machine	kg	61	73	83.2	90.2	122.2

(1) Nominal data based on 35°C ambient and a 50°C mean condensing temperature and using standard fan. All performance data is supplied in accordance with BS EN 14511-1:2013

(2) Overall dimensions for clearance; refer to **Dimensional & Installation Data** for detail.

(3) For guidance only.



## General Specification

### MECHANICAL DATA

		C45HI	CS50	CS65	CS80	CS105
<b>Total Heat of Rejection</b>	(1) kW	46.1	51.8	69.3	84.5	111.3
<b>Dimensions - Horizontal</b>		(2)				
Height	mm	1048	1167	1167	1167	1167
Width	mm	645	1000	1000	1000	1000
Length	mm	1650	2184	2184	3565	3565
<b>Dimensions - Vertical</b>		(2)				
Height	mm	1092	1090	1090	1090	1090
Width	mm	1100	1167	1167	1167	1167
Length	mm	1650	2184	2184	3565	3565
<b>Weight</b>						
Machine	kg	110	132	162	208	260
<b>Construction</b>		Galvanised Sheet Steel, Epoxy Baked Powder Paint - Light Grey (RAL 7035)				
<b>Condenser</b>		Air Cooled - Rifled Copper Tube/Turbulated Aluminium Fins				
Quantity		1	1	1	1	1
Total Face Area	m <sup>2</sup>	1.6	2.11	2.11	3.63	3.63
Nominal Airflow	m <sup>3</sup> /s	4.45	4.8	4.2	7.5	6.6
Discharge		<b>H</b> Horizontal or <b>V</b> Vertical ( <i>Please Specify at Order</i> )				
<b>Fan &amp; Motor</b>				Axial		
Quantity		2	2	2	3	3
Diameter	mm	630	630	630	630	630
Maximum Speed	rpm	900	900	900	900	900
<b>Refrigeration</b>		Single Circuit				
Refrigerant Type		R407C				
Holding Charge		Inert Gas				
Coil Volume	L	15.7	10.7	21.5	18.3	36.7
Refrigerant Charge	(3) kg	6.1	4.3	8.5	7.3	14.6
<b>Connections</b>						
Liquid Line - Sweat	in	7/8	3/4	3/4	7/8	7/8
Discharge Line - Sweat	in	7/8	1 1/8	1 1/8	1 3/8	1 3/8
<b>OPTIONAL EXTRAS</b>		Designed to 75 Pa ESP				
<b>Short Case Axial Fan</b>		Designed to 75 Pa ESP				
<b>Dimensions - Horizontal</b>						
Height	mm	1048	1167	1167	1167	1167
Width	mm	711	1000	1000	1000	1000
Length	mm	1650	2184	2184	3565	3565
<b>Dimensions - Vertical</b>						
Height	mm	1162	1130	1130	1130	1130
Width	mm	1100	1167	1167	1167	1167
Length	mm	1650	2184	2184	3565	3565
<b>Weight</b>						
Machine	kg	147.2	167.2	197.2	255.2	307.2

- (1) Nominal data based on 35°C ambient and a 50°C mean condensing temperature and using standard fan. All performance data is supplied in accordance with BS EN 14511-1:2013
- (2) Overall dimensions for clearance; refer to **Dimensional & Installation Data** for detail.
- (3) For guidance only.

## General Specification

### ELECTRICAL DATA

		C11HI	C15HI	C20HI	C25HI	C35HI
<b>Unit Data</b> (1)						
Nominal Run Amps	A	0.65	1.3	2.8	2.8	2.8
Maximum Start Amps	A	2.6	5.2	5.6	5.6	5.6
Recommended Mains Fuse	A	10	10	10	10	10
Max Mains Cable Incoming	mm <sup>2</sup>	10	10	10	10	10
Mains Supply		230V / 1Ph + N / 50Hz				
<b>Fan - Per Fan</b>						
Quantity		1	2	1	1	1
Motor Size	kW	0.15	0.15	0.59	0.59	0.59
Full Load Amps	A	1.32	0.65	2.8	2.8	2.8
Locked Rotor Amps	A	2.6	2.6	5.6	5.6	5.6
<b>OPTIONAL EXTRAS</b>						
<b>Short Case Axial Fan - Per Fan</b>						
Quantity		1	2	1	1	1
Motor Size	kW	0.60	0.60	1.15	1.15	1.15
Full Load Amps	A	3.6	3.6	8.6	8.6	8.6
Locked Rotor Amps	A	6.5	6.5	25.8	25.8	25.8
Recommended Mains Fuse	A	10	10	10	10	10
<b>EC Fans</b>						
Quantity		N/A	N/A	N/A	N/A	N/A
Motor Size	kW	N/A	N/A	N/A	N/A	N/A
Full Load Amps	A	N/A	N/A	N/A	N/A	N/A
Recommended Mains Fuse	A	N/A	N/A	N/A	N/A	N/A

		C45HI	CS50	CS65	CS80	CS105
<b>Unit Data</b> (1)						
Nominal Run Amps	A	5.6	5.24	5.24	7.86	7.86
Maximum Start Amps	A	11.2	18.34	18.34	27.51	27.51
Recommended Mains Fuse	A	10	10	10	16	16
Max Mains Cable Incoming	mm <sup>2</sup>	10	6	6	6	6
Mains Supply		230V / 1Ph + N / 50Hz				
<b>Fan - Per Fan</b>						
Quantity		2	2	2	3	3
Motor Size	kW	0.59	0.6	0.6	0.6	0.6
Full Load Amps	A	2.8	2.62	2.62	2.62	2.62
Locked Rotor Amps	A	5.6	9.17	9.17	9.17	9.17
<b>OPTIONAL EXTRAS</b>						
<b>Short Case Axial Fan - Per Fan</b>						
Quantity		2	2	2	3	3
Motor Size	kW	1.15	1.15	1.15	1.15	1.15
Full Load Amps	A	8.6	8.6	8.6	8.6	8.6
Locked Rotor Amps	A	25.8	25.8	25.8	25.8	25.8
Recommended Mains Fuse	A	20	20	20	32	32
<b>EC Fans</b>						
Quantity		N/A	2	2	3	3
Motor Size	kW	N/A	0.72	0.72	0.72	0.72
Full Load Amps	A	N/A	3.2	3.2	3.2	3.2
Recommended Mains Fuse	A	N/A	10	10	16	16

(1) Nominal data based on 35°C ambient and a 50°C mean condensing temperature and using standard fan.

### INTERCONNECTING WIRING

C11 - 45	L1	○
	N	○
	E	○

Mains Incoming 230V / 1Ph + N / 50Hz

CS50 - 105	L1	○
	N	○
	PE	○

Mains Incoming 230V / 1Ph + N / 50Hz

## Performance Data

### CAPACITY DATA

#### Standard Condenser Fan

	Mean Condensing Temperature °C	Ambient					
		25°C	30°C	35°C	40°C	45°C	48°C
		Output kW	Output kW	Output kW	Output kW	Output kW	Output kW
C11HI	35	6.90	3.24	-	-	-	-
	40	10.81	6.94	3.26	-	-	-
	45	15.05	10.93	6.97	3.27	-	-
	50	19.31	15.11	10.98	6.99	3.28	-
	55	23.66	19.41	15.18	11.02	7.02	4.78
C15HI	35	10.27	4.76	-	-	-	-
	40	16.21	10.37	4.80	-	-	-
	45	22.28	16.36	10.45	4.83	-	-
	50	28.49	22.51	16.49	10.51	4.85	-
	55	34.95	28.81	22.73	16.61	10.57	7.14
C20HI	35	12.52	5.79	-	-	-	-
	40	19.63	12.70	5.86	-	-	-
	45	26.76	19.93	12.84	5.91	-	-
	50	34.70	27.23	20.18	12.96	5.95	-
	55	42.79	35.22	27.65	20.42	13.07	8.82
C25HI	35	15.98	7.41	-	-	-	-
	40	25.35	16.06	7.44	-	-	-
	45	35.17	25.47	16.13	7.47	-	-
	50	45.22	35.31	25.57	16.18	7.49	-
	55	55.50	45.47	35.47	25.66	16.22	10.99
C35HI	35	19.01	8.84	-	-	-	-
	40	29.39	19.02	8.84	-	-	-
	45	40.15	29.54	19.21	8.84	-	-
	50	50.81	40.15	29.66	19.28	8.84	-
	55	61.77	51.08	40.53	29.93	19.34	13.04
C45HI	35	28.88	13.47	-	-	-	-
	40	45.10	29.22	13.60	-	-	-
	45	61.55	45.64	29.47	13.70	-	-
	50	78.93	62.34	46.09	29.69	13.79	-
	55	96.91	79.84	63.05	46.51	29.89	20.28
CS50	35	31.70	13.61	-	-	-	-
	40	50.53	32.16	14.13	-	-	-
	45	69.27	51.15	32.79	14.76	-	-
	50	88.16	70.02	51.84	33.48	15.38	-
	55	107.28	89.08	70.99	52.68	34.29	23.00
CS65	35	44.30	20.92	-	-	-	-
	40	68.27	44.76	21.43	-	-	-
	45	91.99	68.71	45.27	21.88	-	-
	50	115.85	92.51	69.26	45.90	22.51	-
	55	140.04	116.52	93.21	69.98	46.67	32.35
CS80	35	51.98	22.90	-	-	-	-
	40	82.36	52.84	23.88	-	-	-
	45	112.52	83.36	53.79	24.84	-	-
	50	142.90	113.75	84.50	54.89	25.81	-
	55	173.65	144.39	115.16	85.84	56.19	37.96
CS105	35	71.53	34.06	-	-	-	-
	40	109.82	72.21	34.83	-	-	-
	45	147.74	110.49	73.00	35.50	-	-
	50	185.90	148.51	111.32	73.95	36.48	-
	55	224.58	186.90	149.56	112.42	75.14	52.26

(1) Output kW refers to the condenser heat of rejection.

### OPERATING LIMITS

#### Standard On/Off Head Pressure Control

Minimum Ambient Air DB °C	-0°C
Maximum Ambient Air DB °C	+48

#### Optional Variable Speed Head Pressure Control

Minimum Ambient Air DB °C	-20°C
Maximum Ambient Air DB °C	+48

## Sound Data

### METHOD OF SOUND MEASUREMENT

**Measurement of Sound Data** All sound data quoted has been measured in the third-octave band limited values, using a Real Time Analyser calibrated sound intensity meter in accordance with BS EN ISO9614 Part 1 : 2009.

All Sound Power Levels quoted are calculated from measured sound intensity according BS EN ISO9614 Part 1 : 2009.

**Semi Hemispherical** Sound Pressure Levels are calculated from sound power using the semi-hemispherical method where the noise source is in junction with 2 boundaries i.e. the floor and 1 wall.

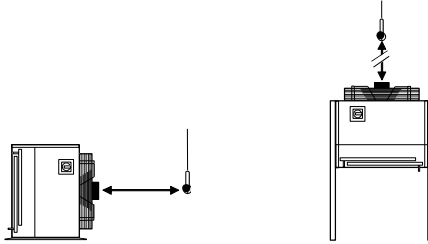

### SOUND DATA

#### Standard Condenser Fan – Horizontal

Sound Measurement	Overall dB(A)	Frequency (Hz) dB								
		63	125	250	500	1000	2000	4000	8000	
C11HI-H	Power dB(A)	67	56	58	63	64	63	61	55	47
	Pressure @ 10m	39	28	30	35	36	35	33	27	19
C15HI-H	Power dB(A)	70	59	61	66	67	66	64	58	50
	Pressure @ 10m	42	31	33	38	39	38	36	30	22
C20HI-H	Power dB(A)	79	78	87	76	73	74	70	62	55
	Pressure @ 10m	51	50	59	48	45	46	42	34	27
C25HI-H	Power dB(A)	79	78	87	76	73	74	70	62	55
	Pressure @ 10m	51	50	59	48	45	46	42	34	27
C35HI-H	Power dB(A)	79	78	87	76	73	74	70	62	55
	Pressure @ 10m	51	50	59	48	45	46	42	34	27
C45HI-H	Power dB(A)	82	81	90	79	76	77	73	65	61
	Pressure @ 10m	54	53	62	51	48	49	45	37	33
CS50H	Power dB(A)	81	84	89	77	77	76	73	66	65
	Pressure @ 10m	53	56	61	49	49	48	45	38	37
CS65H	Power dB(A)	81	84	89	77	77	76	73	66	65
	Pressure @ 10m	53	56	61	49	49	48	45	38	37
CS80H	Power dB(A)	83	80	89	80	77	79	75	68	67
	Pressure @ 10m	55	52	61	52	49	51	47	40	39
CS105H	Power dB(A)	83	80	89	80	77	79	75	68	67
	Pressure @ 10m	55	52	61	52	49	51	47	40	39

#### Standard Condenser Fan – Vertical

Sound Measurement	Overall dB(A)	Frequency (Hz) dB								
		63	125	250	500	1000	2000	4000	8000	
C11HI-V	Power dB(A)	68	53	61	63	64	64	62	56	48
	Pressure @ 10m	40	25	33	35	36	36	34	28	20
C15HI-V	Power dB(A)	71	56	64	66	67	67	65	59	51
	Pressure @ 10m	43	28	36	38	39	39	37	31	23
C20HI-V	Power dB(A)	80	75	92	76	73	75	71	63	56
	Pressure @ 10m	52	47	64	48	45	47	43	35	28
C25HI-V	Power dB(A)	80	75	92	76	73	75	71	63	56
	Pressure @ 10m	52	47	64	48	45	47	43	35	28
C35HI-V	Power dB(A)	80	75	92	76	73	75	71	63	56
	Pressure @ 10m	52	47	64	48	45	47	43	35	28
C45HI-V	Power dB(A)	83	78	95	79	76	78	74	66	62
	Pressure @ 10m	55	50	67	51	48	50	46	38	34
CS50V	Power dB(A)	83	81	93	77	77	78	74	68	67
	Pressure @ 10m	55	53	65	49	49	50	46	40	39
CS65V	Power dB(A)	83	81	93	77	77	78	74	68	67
	Pressure @ 10m	55	53	65	49	49	50	46	40	39
CS80V	Power dB(A)	84	76	93	80	78	81	76	70	69
	Pressure @ 10m	56	48	65	52	50	53	48	42	41
CS105V	Power dB(A)	84	76	93	80	78	81	76	70	69
	Pressure @ 10m	56	48	65	52	50	53	48	42	41

1 Figures quoted using standard condenser fan(s) running at full speed under normal operating conditions.

## Dimensional & Installation Data

### DIMENSIONS / MASSES / POSITIONING - HORIZONTAL

#### Standard Condenser Fan (mm) (C11 Shown)

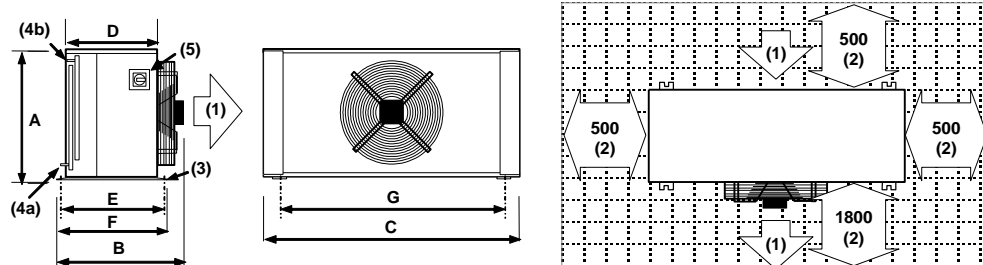

#### Optional Short Case Axial Fan (mm) (SCAF) (C45 Shown)

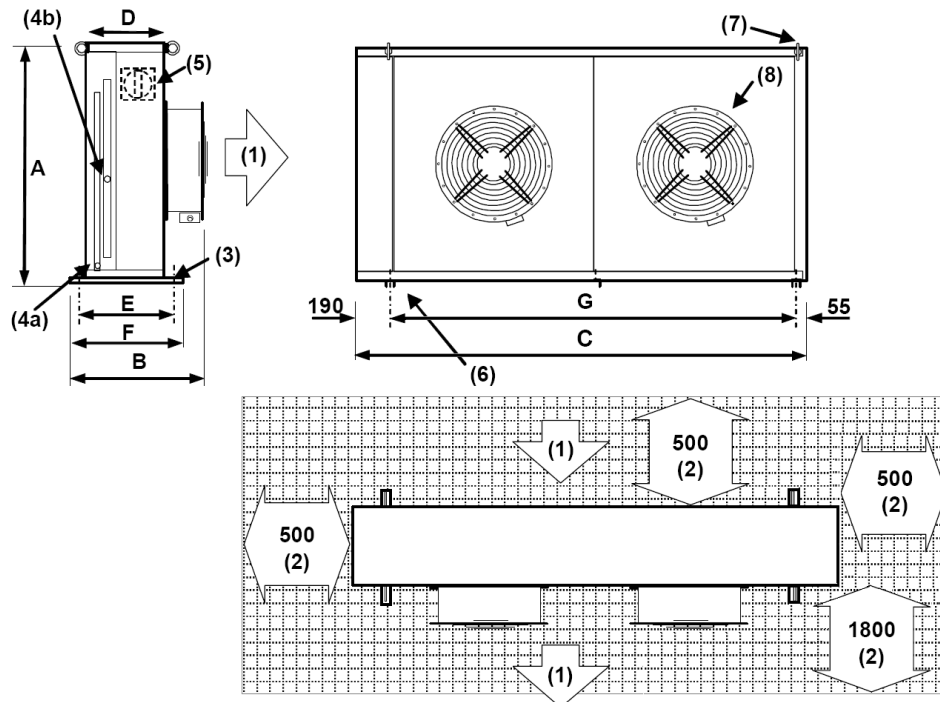

	DIMENSIONS (mm)									MASS (kg)		
	Standard Fan								Optional SCAF		Standard Fan	Optional SCAF
	A	B	C	D	E	F	G	G <sup>(6)</sup>	B	F		
C11HI-H	648	550	1275	455	530	550	1118	N/A	675	640	51	61
C15HI-H	648	550	1275	455	530	550	1118	N/A	675	640	63	73
C20HI-H	848	645	1100	455	530	550	944	N/A	735	640	58	70
C25HI-H	848	645	1100	455	530	550	944	N/A	735	640	65	77
C35HI-H	1048	645	1650	455	530	550	1494	N/A	711	640	97	109
C45HI-H	1048	645	1650	455	530	550	1494	N/A	711	640	110	134

- (1) Airflow
- (2) Minimum clearances in mm
- (3) 8mm fixing points
- (4) **Service connections to left hand side of the unit: a = Liquid Outlet, b = Discharge Gas Inlet**
- (5) Mains Electric Isolator, (CS50 – C105 located behind open side panel)
- (6) Additional support to sizes C80 – CS105
- (7) 4 lifting eye bolts to unit top, sizes CS50 – CS105
- (8) Optional Short Case Axial Fan with integral duct fixing holes

## Dimensional & Installation Data

### DIMENSIONS / MASSES / POSITIONING - VERTICAL

#### Standard Condenser Fan (mm) (C11 Shown)

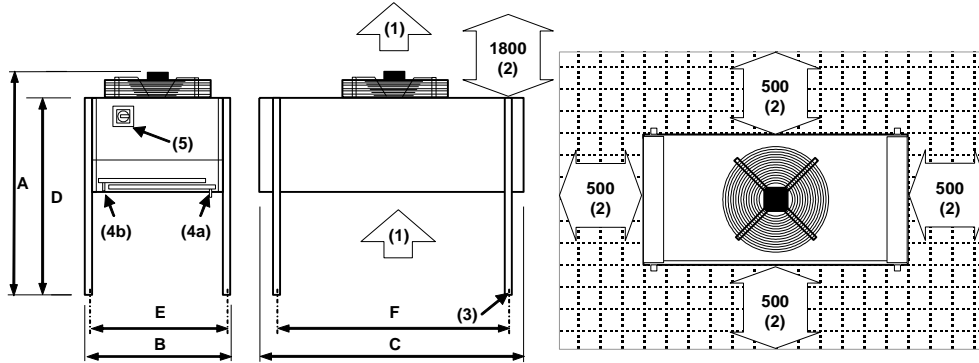

#### Optional Short Case Axial Fan (mm) (SCAF) (C45 Shown)

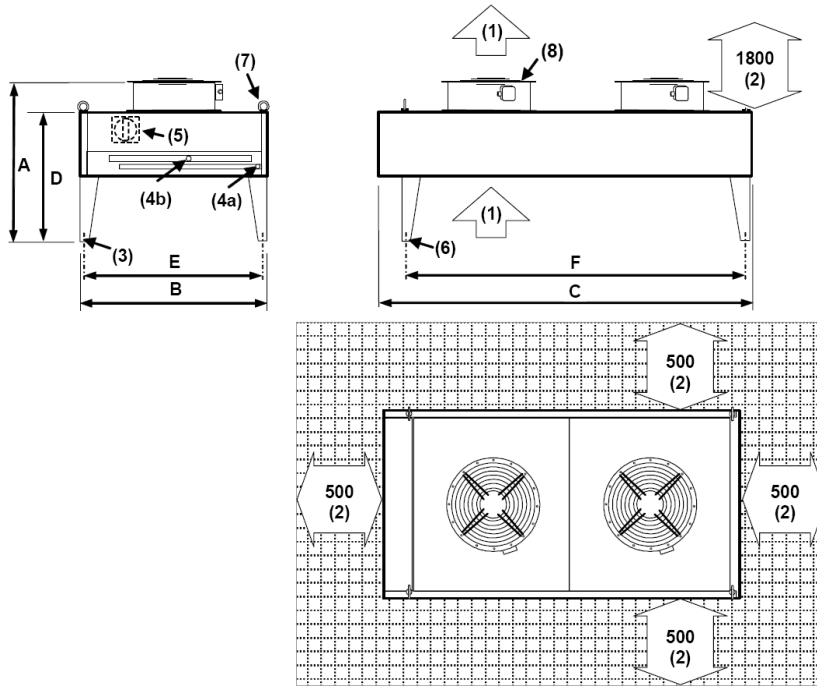

	DIMENSIONS (mm)							MASS (kg)		
	Standard Fan							Optional SCAF	Standard Fan	Optional SCAF
	A	B	C	D	E	F	F1(6)	A		
C11HI-V	997	700	1275	952	630	1118	N/A	1112	51	61
C15HI-V	997	700	1275	952	630	1118	N/A	1112	63	73
C20HI-V	1092	900	1100	952	830	944	N/A	1162	58	70
C25HI-V	1092	900	1100	952	830	944	N/A	1162	65	77
C35HI-V	1092	1100	1650	952	1030	1494	N/A	1162	97	109
C45HI-V	1092	1100	1650	952	1030	1494	N/A	1162	110	134

- (1) Airflow
- (2) Minimum clearances in mm
- (3) 8mm fixing points
- (4) Service connections to left hand side of the unit: a = Liquid Outlet, b = Discharge Gas Inlet
- (5) Mains Electric Isolator, (CS50 – CS105 located behind open side panel)
- (6) Additional support to sizes CS80- CS105
- (7) 4 lifting eye bolts to unit top, sizes CS50 – CS105
- (8) Optional Short Case Axial Fan with integral duct fixing holes

## DIMENSIONS CS50 - 65

### Horizontal Unit (mm)

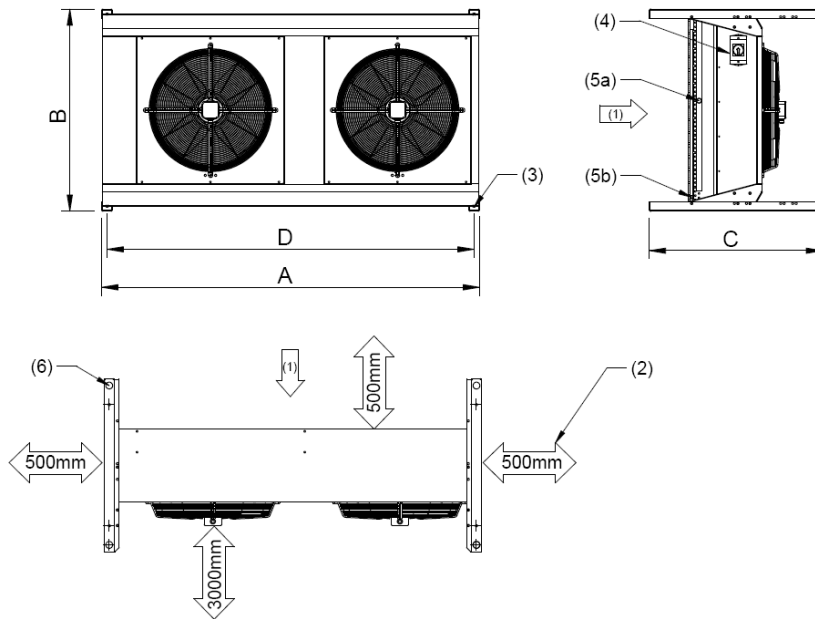

- (1) Airflow
- (2) Minimum Clearances
- (3) 12.7mm Fixing Holes
- (4) Mains Electric Isolator.
- (5) Service connections
  - a) Liquid Outlet
  - b) Discharge Inlet
- (6) 40mm Lifting Holes

	DIMENSIONS (mm)				MASS (kg)		
	A	B	C	D	Standard AC	Optional EC	Optional SCAF
CS50H-0 mm	2184	1167	1000	2121	132	145	154
CS65H-0 mm	2184	1167	1000	2121	162	175	184

### Vertical Unit (mm)

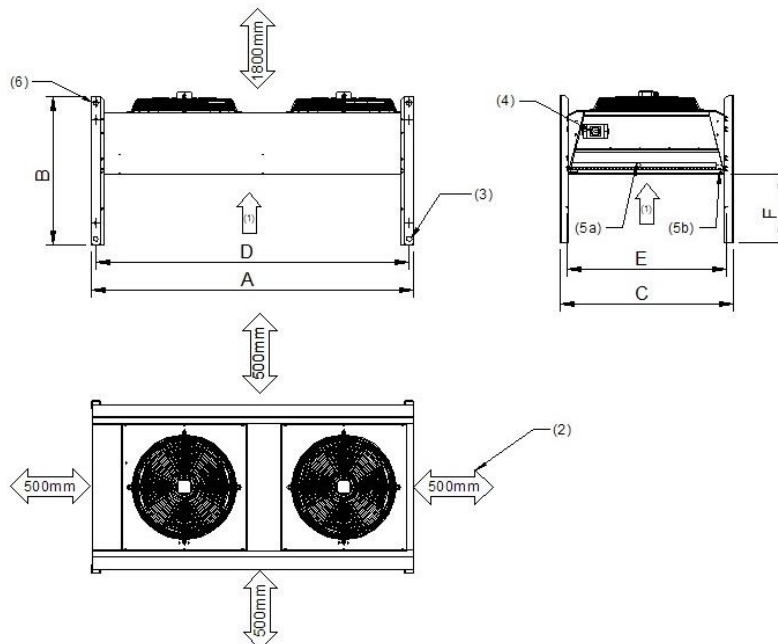

- (1) Airflow
- (2) Minimum Clearances
- (3) 12.7mm Fixing Holes
- (4) Mains Electric Isolator.
- (5) Service connections
  - a) Liquid Outlet
  - b) Discharge Inlet
- (6) 40mm Lifting Holes

	DIMENSIONS (mm)							MASS (kg)			
	Standard Fan				Fan Options			Standard AC	Optional EC	Optional SCAF	
	A	B	C	D	E	F	EC Opt. B				SCAF Opt. B
CS50V-0 mm	2184	1090	1167	2124	1107	467	1130	1127	132	145	154
CS65V-0 mm	2184	1090	1167	2124	1107	467	1130	1127	162	175	184

## DIMENSIONS CS80 - 105

### Horizontal Unit (mm)

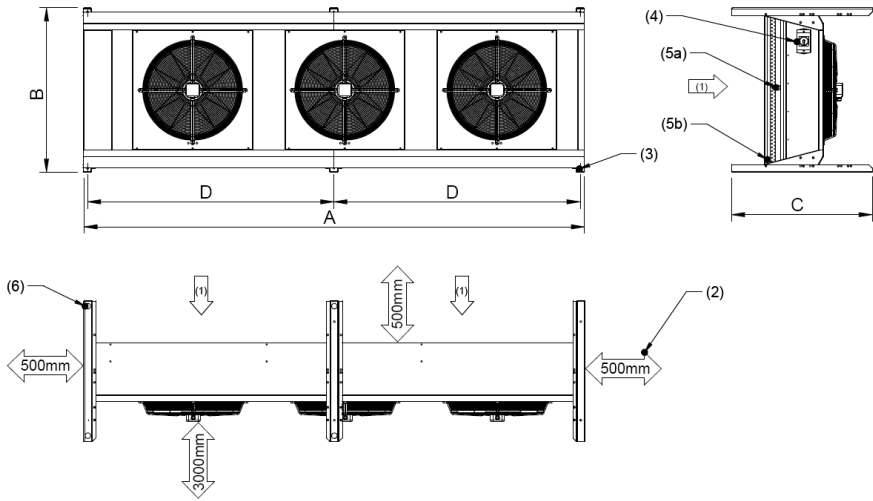

- (1) Airflow
- (2) Minimum Clearances
- (3) 12.7mm Fixing Holes
- (4) Mains Electric Isolator.
- (5) Service connections
  - a) Liquid Outlet
  - b) Discharge Inlet
- (6) 40mm Lifting Holes

		DIMENSIONS (mm)				MASS (kg)		
		Standard Fan				Standard AC	Optional EC	Optional SCAF
		A	B	C	D			
CS80H-0	mm	3565	1167	1000	1752	208	228	242
CS105H-0	mm	3565	1167	1000	1752	260	280	294

### Vertical Unit (mm)

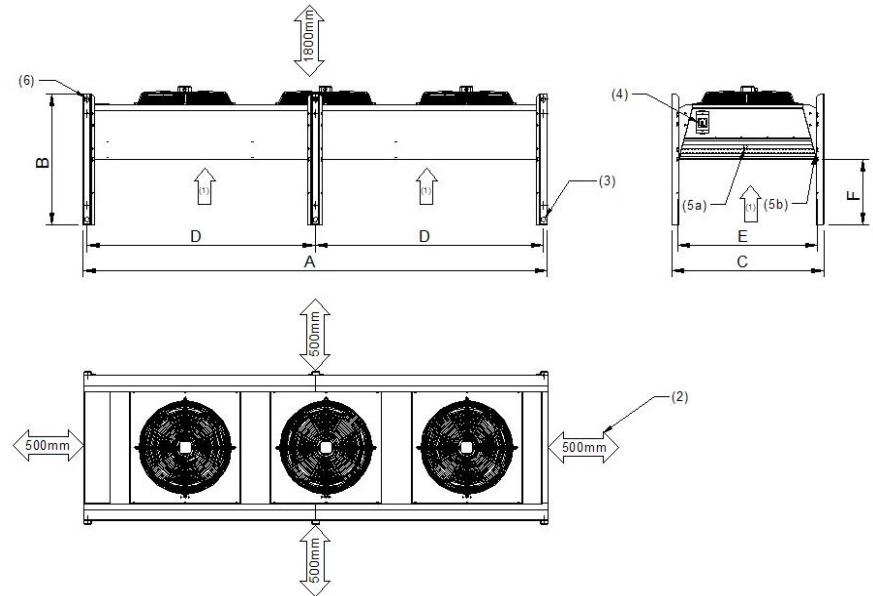

- (1) Airflow
- (2) Minimum Clearances
- (3) 12.7mm Fixing Holes
- (4) Mains Electric Isolator.
- (5) Service connections
  - a) Liquid Outlet
  - b) Discharge Inlet
- (6) 40mm Lifting Holes

		DIMENSIONS (mm)							MASS (kg)				
		Standard Fan							Fan Options		Standard AC	Optional EC	Optional SCAF
		A	B	C	D	E	F	EC Opt. B	SCAF Opt. B				
CS80V-0	mm	3565	1090	1167	1753	1107	501	1130	1127	208	228	242	
CS105V-0	mm	3565	1090	1167	1753	1107	501	1130	1127	260	280	294	



## UNIT LIFTING

**Horizontal Air Discharge** The unit is delivered in horizontal air discharge configuration secured to a pallet. Where possible the unit should be moved with the pallet in place.

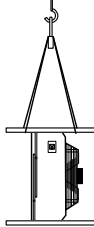

Lift via 4 slings placed over the top corner legs as indicated

**Vertical Air Discharge** The unit is delivered in horizontal air discharge configuration secured to a pallet. Where possible the unit should be moved with the pallet in place.

Before lifting into final position, the unit legs should be re-orientated, instructions for this are provided at delivery

**CAUTION**  Care should be taken to ensure the unit does not sustain damage before it is lifted into final position.

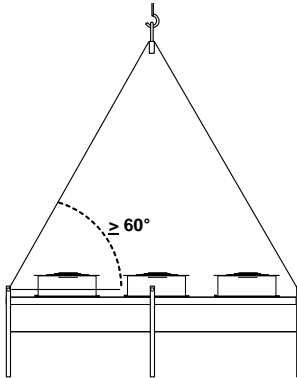

Lift via 4 slings (provided by others) attached to the lifting holes provided to the 4 corner legs as indicated

## General

Employ lifting specialists  
Local codes and regulations relating to the lifting of this type of equipment should be observed  
Use the lifting holes provided - Vertical air discharge only  
Each chain/sling must be capable of lifting the whole unit  
Lift the unit slowly and evenly

**CAUTION**  Only use lifting points provided.

If any other type of slinging is used, due care should be taken to ensure that the slings do not crush the casework or coil.

**CAUTION**  If the unit is dropped, it should immediately be checked for damage and reported to Airedale.

## SITING RECOMMENDATIONS

**Horizontal Air Discharge** Avoid where possible siting the unit where wind and air re-circulation may interfere with the fan operation

A vertical air discharge unit is recommended for installation in windy locations or wherever a horizontal airflow would be obstructed



Notes:







**Head Office:**

**Airedale International Air Conditioning Ltd**  
Leeds Road  
Rawdon  
Leeds LS19 6JY  
United Kingdom

**Tel:** +44 (0) 113 239 1000  
**Fax:** +44 (0) 113 250 7219

**e-mail:** [enquiries@airedale.com](mailto:enquiries@airedale.com)  
**website:** [www.airedale.com](http://www.airedale.com)



<b>PART NO:</b>	<b>ISSUE</b>	<b>DATE</b>
<b>6469597</b>	<b>A</b>	<del>01/11/06</del>
	<b>B</b>	01/05/07
	1.2.0	08/2011
	1.3.0	02/2013
	1.4.0	10/2013
	1.6.0	10/2014
	1.7.0	10/2015
	1.8.0	11/2015
	1.9.0	03/2016
	1.10.0	07/2017