

LogiCool™

FreeCooling Chiller

20kW - 40kW

R410A



TECHNICAL MANUAL



FM00542

EMS52086

About Airedale Products & Customer Services

WARRANTY

All AIAC products or parts (non consumable) supplied for installation within the UK mainland and commissioned by an AIAC engineer, carry a full Parts & Labour warranty for a period of 12 months from the date of commissioning or 18 months from the date of despatch, whichever is the sooner.

Parts or Equipment supplied by AIAC for installation within the UK or for Export that are properly commissioned in accordance with AIAC standards and specification, not commissioned by an AIAC engineer; carry a 12 month warranty on non consumable Parts only from the date of commissioning or 18 months from the date of despatch, whichever is the sooner.

Parts or equipment installed or commissioned not to acceptable AIAC standards or specification invalidate all warranty.

Warranty is only valid in the event that

In the period between delivery and commissioning the equipment: is properly protected & serviced as per the AIAC installation & maintenance manual provided where applicable the glycol content is maintained to the correct level.

In the event of a problem being reported and once warranty is confirmed as valid under the given installation and operating conditions, the Company will provide the appropriate warranty coverage (as detailed above) attributable to the rectification of any affected Airedale equipment supplied (excluding costs for any specialist access or lifting equipment that must be ordered by the customer).

Any spare part supplied by Airedale under warranty shall be warranted for the unexpired period of the warranty or 3 months from delivery, whichever period is the longer.

To be read in conjunction with the Airedale Conditions of Sale - Warranty and Warranty Procedure, available upon request.

CAUTION



Warranty cover is not a substitute for maintenance. Warranty cover is conditional to maintenance being carried out in accordance with the recommendations provided during the warranty period. Failure to have the maintenance procedures carried out will invalidate the warranty and any liabilities by Airedale International Air Conditioning Ltd.

SPARES

A spares list for 1, 3 and 5 years will be supplied with every unit and is also available from our Spares department on request.

TRAINING

As well as our comprehensive range of products, Airedale offers a modular range of Refrigeration and Air Conditioning Training courses, for further information please contact Airedale.

CUSTOMER SERVICES

For further assistance, please e-mail: enquiries@airedale.com or telephone:

UK Sales Enquiries	+ 44 (0) 113 238 7789	enquiries@airedale.com
International Enquiries	+ 44 (0) 113 239 1000	enquiries@airedale.com
Spares Hot Line	+ 44 (0) 113 238 7878	spares@airedale.com
Airedale Service	+ 44 (0) 113 239 1000	service@airedale.com
Technical Support	+ 44 (0) 113 239 1000	tech.support@airedale.com
Training Enquiries	+ 44 (0) 113 239 1000	marketing@airedale.com

For information, visit us at our Web Site: www.airedale.com

AIAC Ltd endeavours to ensure that the information in this document is correct and fairly stated, but none of the statements are to be relied upon as a statement or representation of fact. AIAC Ltd does not accept liability for any error or omission, or for any reliance placed on the information contained in this document.

The development of Airedale products and services is continuous and the information in this document may not be up to date. It is important to check the current position with AIAC Ltd at the address stated. This document is not part of a contract or licence unless expressly agreed.

No part of this document may be reproduced or transmitted in any form or by any means, electronic or mechanical, including photocopying, recording, or information storage and retrieval systems, for any purpose other than the purchaser's personal use, without the express written permission of AIAC Ltd.

© 2018 Airedale International Air Conditioning Limited. All rights reserved. Printed in the UK.

Contents

Warranty	2
General Description	4
Unit Identification	4
Introduction	4
Refrigerant	4
Construction	5
Standard Features - Energy Saving	5
Standard Features - General	7
Optional Extras - Energy Saving	8
Optional Extras - General	8
Design Features & Information	10
Electronic Expansion Valves (EEV)	10
Digital Scroll Compressors	11
Pipework design	12
Minimum System Water Volume Calculations	13
Temperature Control	16
Monitoring	17
Performance Data	18
ESEER Calculations	18
FSEER Calculations	18
Capacity Data - DX (Mechanical) Cooling	19
Operating Limits	19
Capacity Data - Free Cooling	20
Glycol Data	22
Waterside Pressure Drop (kPa)	23
Pump Packages (Optional Extras)	24
Sound Data	26
Measurement of Sound Data	26
Sound Data	27
General Specification	28
Mechanical Data	28
Electrical Data	29
Dimensional Data	30
Dimensions	30
Weights	30
Installation Data	31
Unit Lifting	31
Positioning	32
Water System	32
Standard Recommended Installation	33
Pump Packages (Optional Extras)	34
Electrical	35
Interconnecting Wiring	35

General Description

UNIT IDENTIFICATION

LCC	LogiCool Free-Cooling Chiller	LCC	20
20 - 40	Model Size (Expressed as Nominal Cooling in kW)		

Introduction

The Airedale range of LogiCool Compact air cooled liquid chillers covers the nominal capacity range 20kW to 40kW in 2 model sizes.

This range has been developed for high heat load requirements and is ideally suited to Server room applications. Offering simultaneous DX Mechanical cooling and Free-Cooling operation, the range utilises the latest technology to achieve a high level of energy efficient operation.

As standard, the LogiCool offers modulating capacity control through the use of digital scroll compressor technology and further increased energy efficiency with optional EC Fans, refer to **Optional Extras - Energy Saving**, on page 8 for details.

Attention has been placed on maximising the unit's cooling and energy performance while keeping the footprint to an absolute minimum.

CE Directive



Airedale certify that the equipment detailed in this manual conforms with the following EC Directives:

Electromagnetic Compatibility Directive (EMC)	2014/30/EU
Machinery Directive (MD)	89/392/EEC in the version 2006/42/EC
Pressure Equipment Directive (PED)	2014/68/EU

PS and TS Values

To comply with these directives appropriate national & harmonised standards have been applied. These are listed on the Declaration of Conformity, supplied with each product.

Maximum and Minimum Operation Temperature (TS) and Pressure (PS) Refrigeration

Allowable Temperature Range (TS), = Min -20°C to Max 120°C *

Maximum Allowable Pressure (PS),= High Side 40.7 Barg

*Based on the refrigerant temperature in the unit off state in the lowest permitted ambient temperature.'

**Based on the maximum allowable super-heated refrigerant temperature.

Waterside

Allowable Temperature Range (TS),= Min -5°C to Max 40°C *

Maximum Allowable Pressure (PS) = 10 Barg

*Based on the waterside temperature in the unit off state in the lowest permitted ambient temperature.'

**Based on the waterside temperature in the unit off state in the highest permitted ambient temperature.

Global Warming Potential

The R410A refrigerant has a GWP of 2088, (Based on EN378-1:2016, 100 year life)

Units within this range are non-Ecodesign compliant but can be used in process applications that are above >12°C supply water temperature, as these fall outside the Ecodesign parameters. Products sold outside of the EU are exempt from this directive. Please refer to your Airedale account manager for full details.

Ecodesign Directive 2009/125/EC

Refrigerant

The range has been designed and optimised for operation with ozone benign refrigerant **R410A**.

General Description

Construction

The base is fabricated from galvanised steel coated with epoxy baked powder paint to ensure a durable, weatherproof construction.

Unit panels are manufactured from galvanised sheet steel coated with epoxy baked powder paint to provide a durable and weatherproof finish.

Standard unit colour is Light Grey (RAL 7035).

Fully weatherproofed electrical panels are situated at one end of the unit.

Access to the water and refrigeration components is via the lower front panel.

Coil guards are fitted as standard.

A set of 4 collared eye bolts to BS4278 are supplied.

STANDARD FEATURES - ENERGY SAVING

Compressor

Scroll compressor(s) comprising:

- Internal motor protection
- Internal pressure relief
- External discharge temperature protection
- Oil sight glass

LCC20

Utilises 1 digital scroll compressor offering modulating capacity control between 20 - 100% of unit capacity.

LCC40

Utilises 1 digital scroll compressor coupled in tandem with 1 standard scroll compressor offering modulating capacity control between 10 - 100% of unit capacity.

Energy saving digital compressors enable capacity modulation through time averaging of the loaded and unloaded state of the compressor scroll. For further details, please refer to **Design Features & Information**, on page 11.

Electronic Expansion Valves (EEV)

Electronic expansion valves differ to the normal thermostatic expansion valves in their ability to maintain control of the suction superheat at reduced head pressures. This can lead to significant energy savings particularly at reduced loading and low ambient temperatures. Factory fitted, for full details refer to the **Design Features & Information**, on page 10.

General Description

STANDARD FEATURES - ENERGY SAVING

- Evaporator** Stainless steel high efficiency brazed plate heat exchanger(s) will allow optimum heat transfer between media. Each heat exchanger is insulated with closed cell polyurethane foam to Class 1 fire rating and the material is UV resistant.
- A self-regulating pad heater is fitted to the single evaporator and will protect against freeze up in ambient temperatures as low as -20°C.
- Condenser** Large surface area coil(s) ideally positioned to optimise airflow and heat transfer, manufactured from refrigeration quality copper tubes with mechanically bonded aluminium fins.
- The copper tube is internally rifled for improved heat transfer.
- Free-Cooling Coil** Large surface area coil(s) ideally positioned to optimise airflow and heat transfer, manufactured from refrigeration quality copper tubes with mechanically bonded aluminium fins.
- Spacing between condenser and free-cooling coils is provided for cleaning maintenance along with top access holes and drain holes to the base.
- Fan & Motor Assembly** Sickle bladed fan assemblies with integral long bellmouth and fingerproof grille; incorporate external rotor ac motor technology, capable of highly accurate discreet speed control, discharges air vertically. The fans offer maximum airflow performance while keeping sound levels to a minimum.
- Each fan is speed controllable and operates from a 3 phase electrical supply.
- Energy efficient Electronically Commutated (EC) fans are also available; refer to **Optional Extras - Energy Saving**, on page 8.
- Head Pressure Control** 3 phase head pressure controllers are fitted which modulate the fan speed to maintain a constant condensing pressure in the DX mechanical cooling mode and afford reductions in input power when overcooling in low ambients.
- A pressure transducer is fitted to the liquid line which in turn feeds back the head pressure to the microprocessor. The condenser fan speed can then modulate via the controller to provide optimum control under varying ambient conditions. The head pressure can be monitored via the display keypad.
- Additional refrigeration valves are fitted to allow mechanical and free-cooling functions to operate simultaneously in order to maximise free-cooling and minimise energy consumption.

General Description

STANDARD FEATURES - GENERAL

Refrigeration

Each refrigeration circuit is supplied with the following:

- Full operating charge of R410A
- Electronic Expansion Valve (EEV)
- Liquid line ball valve
- Discharge line ball valve
- Liquid line filter drier
- Liquid line sight glass
- Low pressure switch with manual reset via microprocessor controller
- High pressure switch with manual reset
- Suction and liquid pressure transducers
- Valves for refrigeration head pressure control

Water / Glycol

Each water glycol circuit is supplied with the following:

- 3 way modulating valve to control free-cooling operation
- Strategically placed automatic air vents
- Strategically placed drain valves
- Ball valve(s) for Free-cooling coil isolation to allow for maintenance
- Pressure transducer(s) across evaporator to monitor water pressure drop
- Inlet water filter ball valve 20 mesh

Flushing Bypass Kit (Standard)

Comprises:

- Shut off valves

Factory fitted to protect the evaporator from clogging by sediment and to enable the system to be purged before running.

Controls

As standard, the **AIRETronix** microprocessor controller can provide modulating capacity control.

Optionally, the controller is designed to provide capabilities for;

- Building Management Systems

to meet all your system requirements, please confirm at time of order.

Evaporator Differential Pressure Sensor

Facilitates low flow limiting and pressure drop monitoring via the microprocessor.

Measures the evaporator pressure drop which in turn enables the evaporator flow rate to be calculated.

General Description

STANDARD FEATURES - GENERAL

- Electrical** Dedicated weatherproof electrical power and controls panels are situated at the front of the unit and contain:
- Separate, fully accessible, controls compartment
 - Circuit breakers for protection of all major unit components
 - Separate, permanent supply for controls/trace heating, 230V / 50Hz / 1Ph

CAUTION  **A fused and isolated electrical supply of the appropriate phase, frequency and voltage should be installed.**

The electrical power and control panel is wired to the latest European standards and codes of practice.

Mains supply is 3 phase and a neutral is not required. Refer to Interconnecting Wiring, on page 35.

Electrical terminals for external evaporator pipework trace heating (240V/500W) are provided.

OPTIONAL EXTRAS - ENERGY SAVING

- Electronic Soft Start** The electronic soft start enables the chiller compressor motor to be ramped to speed with the minimum full load current. Further benefits include removal of nuisance tripping, supply voltage dips and motor overheating.

- Electronically Commutated (EC) Fan Motor** Sickle bladed fan assemblies with integral long bellmouth and fingerproof grille. Incorporate external EC rotor motor technology, to provide highly accurate discreet speed control, discharge air vertically. The fans offer maximum airflow performance while keeping sound levels to a minimum.

Each fan incorporates on board electronics with inverter-driven DC motor control, responding to a signal from the unit microprocessor.

For further details, please refer to *Design Features & Information*, on page 12.

- Energy Manager** Analysis of system energy consumption can be monitored via a dedicated LCD display. Unit parameters can be adjusted via the unit microprocessor control to affect energy usage in line with the system need.

OPTIONAL EXTRAS - GENERAL

- Corrosion Resistant Coated Coils** In atmospheres where high corrosion is anticipated a corrosion resistant coating is applied to the aluminium fins of either phenolic or epoxy, dependent upon size.

- BMS Interface Card** Enables **AIRETronix** controlled chillers to be interfaced with most BMS, including Airedale's own pCOWeb, factory fitted, please contact Airedale.

- R410A Leak Detection System** A factory calibrated and fitted leak detection system, will raise an alarm when refrigerant gas is detected.

General Description

OPTIONAL EXTRAS - GENERAL

Phase Rotation Protection	A phase sequence relay is available for units containing 3 phase scroll compressors, to prevent possible damage by running the compressor in the wrong direction.
Control Panel Low Ambient Protection	Supplementary heating can be offered to the control panel to ensure components such as LCD displays operate in low ambients conditions.
Remote Setpoint Adjust	Allows the chilled water setpoint to be adjusted via an external 0-10V signal.
Compressor Oil Heater	A compressor mounted sump heater is available for low temperature applications.
Flushing Bypass Kit (Regulating)	<p>Comprises:</p> <ul style="list-style-type: none"> • Double regulating valve <p>Factory fitted to protect the evaporator from clogging by sediment and to enable the system to be purged before running.</p> <p>The regulating Flushing Bypass Kit additionally allows the chiller to run with a lower ΔT (typically for chilled beam and/or high water temperature applications).</p>
Internal Pump Packages	Integral pumps may be fitted, standard or larger sizes selected to suit installed system requirements. The following configurations are available:
Single Head Pump	Factory fitted with electrical switchgear and isolating valve.
Single Head Run/Standby Pumps	<p>Factory fitted dual pumps with filter ball valves on the inlet and outlet, the valves can be maintained without interrupting chiller flow. Non-return valves are fitted to the outlet in automatic changeover configuration. Supplied with electrical switchgear and isolating valve.</p> <p>The microprocessor can be programmed to automatically rotate usage of the run/standby pumps to a set period.</p> <p>Refer to Performance Data, on page 24 and Installation Data, on page 34 for further details.</p>
Expansion Vessel	<p>An integral expansion vessel can be factory fitted.</p> <p>All vessels and pipework are trace heated.</p>
Commissioning	Airedale Service provides a full commissioning service carried out by professionally trained, industry experienced engineers. For a competitive quotation, please contact Airedale Customer Services.
Chillerguard® UK Mainland	In addition to commissioning, a 24 hour, 7 days a week on-call service is available throughout the year to UK mainland sites. This service will enable customers to contact a duty engineer outside normal working hours and receive assistance over the telephone. The duty engineer can, if necessary, attend site, usually within 24 hours or less. Full details will be forwarded on acceptance of the maintenance agreement.

Design Features & Information

ELECTRONIC EXPANSION VALVES (EEV)

Thermostatic Expansion Valves (TEV) Whilst offering versatile control at the full design duty of the unit, standard TEVs do not automatically optimise themselves to all operating conditions. Therefore, if the refrigeration system is operating at 40% or 50% of full load, especially at a lower ambient temperature than that for which the valve was sized, the conventional TEV must have the design head pressure available to ensure good refrigerant control. Maintaining an artificially high condensing pressure is normal in conventional systems.

Electronic Expansion Valves (EEV) Using an EEV allows for good refrigeration control whilst operating at part load and lower ambient conditions with a reduced condensing pressure. By fitting an EEV and adjusting the head pressure control setting **an increase in the system EER (Energy Efficiency Ratio) of up to 30% can typically be seen.** The Mollier diagram shown below helps to illustrate how this increase in efficiency is achieved.

EEV's differ to normal thermostatic expansion valves in their ability to maintain control of refrigerant flow and the suction superheat at reduced head pressures. The turn-down rate of a typical EEV is superior to that of its thermostatic equivalent, such that a reduced optimum condensing pressure can be maintained at low compressor load. However low the load is on the compressor, from zero to 100%, there will not be a problem with turn down, even down to 10% of the valves rated capacity.

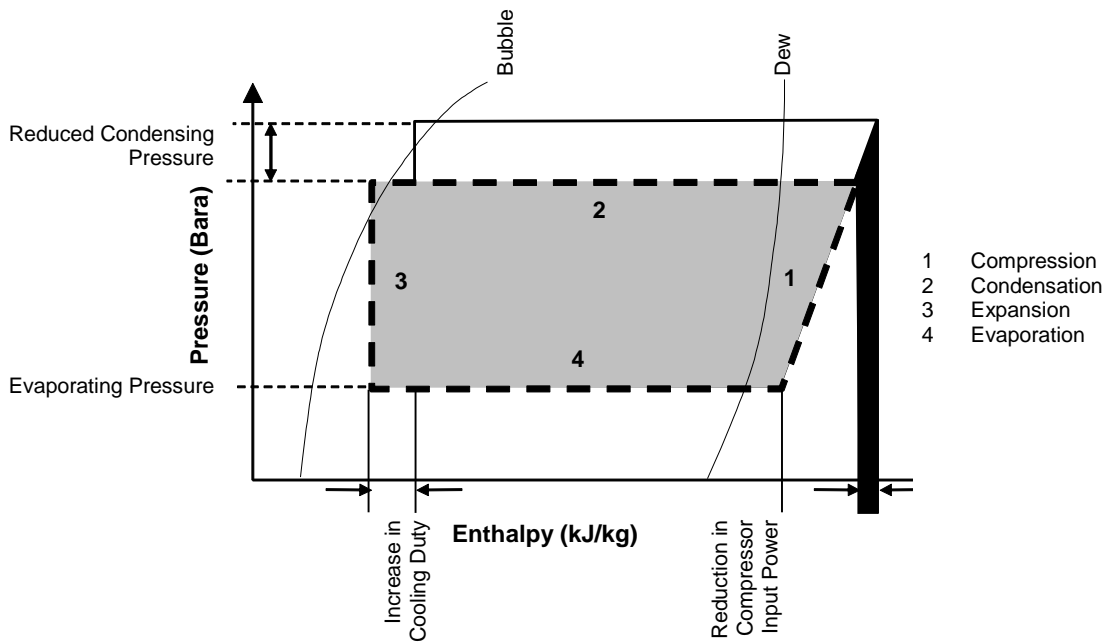

Key
 ——— Cooling Cycle @ 22°C ambient with a conventional TEV fitted.
 - - - Cooling cycle @ 22°C ambient, demonstrating a typical EEV condensing temperature taking full advantage of lower ambient air temperatures (below 30°C).

Design Features & Information

DIGITAL SCROLL COMPRESSORS

General Description

Digital scroll compressor technology offers compressor capacity modulation from 20% to 100% achieved by the use of an externally integrated long life electronically controlled solenoid valve which loads and unloads the compressor scroll based on a 20 second cycle.

The solenoid valve uses suction and discharge pressures through a modulation chamber to cause a spring loaded piston attached to the top scroll to fall down at high pressure and move up at low. The moving of the piston separates the scrolls and results in no compression of refrigerant.

As the digital compressor is always operating at either 100% or 0% the mass flow of refrigerant through the system is always high, simplifying component selection and pipe work design to guarantee oil return.

Energy Efficiency

The digitally modulated solenoid achieves capacity modulation of 20% to 100% by varying the loaded or unloaded compressor cycle time and averaging the sum of the loaded and unloaded state. The digital scroll compressor operates in an unloaded state for a proportion of the 20 second cycle time; as a result, the load on the compressor is greatly reduced as refrigerant is not drawn. Consequently the energy consumed at partial load condition is only a percentage of that consumed during full load condition, ie:

$$\frac{(\text{Loaded Time} \times 100\%) + (\text{Unloaded Time} \times 10\%)}{(\text{Loaded Time} + \text{Unloaded Time})} = \text{Average Power}$$

Operation

The following examples illustrate the flexibility of the digital compressor loading stages within the 20 second cycle time:

Example A

Where: Solenoid Energised = 10 seconds Loaded Time
Solenoid De-energised = 10 seconds Unloaded Time

$$\frac{(10 \times 100\%) + (10 \times 0\%)}{20} = 50\%$$

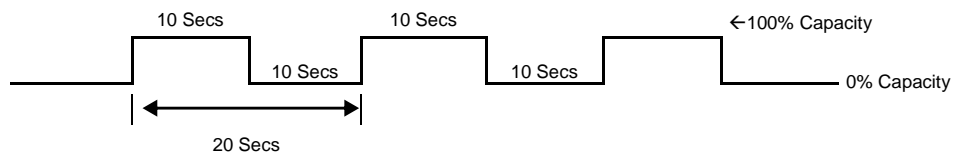

Example B

Where: Solenoid Energised = 5 seconds Loaded Time
Solenoid De-energised = 15 seconds Unloaded Time

$$\frac{(15 \times 100\%) + (5 \times 0\%)}{20} = 75\%$$

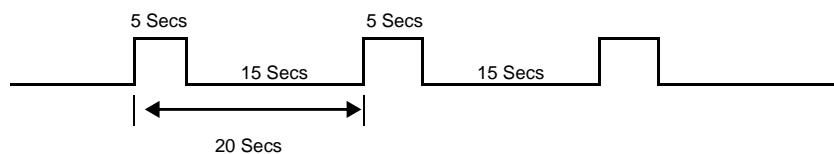

Design Features & Information

DIGITAL SCROLL COMPRESSORS

Control & Monitoring

The systems superheat is controlled by a dedicated microprocessor and digital compressor performance is monitored via the AireTronix controller display.

CAUTION

The digital scroll compressor is always operating at either 100% or 0% mass flow. When inspecting the refrigerant system with gauges, this is evident by pulsing of the system pressures. Therefore, all pressure measurements MUST be taken when the digital scroll compressor is compressing refrigerant (solenoid de-energised).

ELECTRONICALLY COMMUTATED (EC) FAN MOTOR OPTION

EC motors are DC motors with integrated ac to DC conversion; this gives the flexibility of connecting to ac mains with the efficiency and simple speed control of a DC motor. The EC fan offers significant power reduction in comparison with equivalent ac fan at both full and modulated fan speeds. The inbuilt EC fan control module allows for fan speed modulation from 0-100%, a standard ac fans modulating range is typically 40-100% of full fan speed.

The EC fan offers superior energy efficiency at full and reduced fan speed compared to the equivalent ac fan motor.

PIPEWORK DESIGN

The unit refrigeration piping has been specifically designed to ensure the absolute minimum pressure loss. Sizing and layout of pipes is such that good oil circulation is achieved and neither performance nor efficiency is compromised.

Design Features & Information

MINIMUM SYSTEM WATER VOLUME CALCULATIONS (DX Mechanical Cooling Mode Requirements)

General System fluid 20% ethylene glycol / 80% water.

METHOD 1

Where the system permanent heat load is known and the preferred method:

$$V_m (l) = \frac{\text{Water Flow Rate (l/min)}}{\text{Minimum Compressor Run Time (min)}} \times \text{Chiller Loading Factor (1)}$$

$$V_m (l) = \left\{ \frac{\text{Output} \times 60}{\text{SHC} \times \Delta T} \right\} \times 2 \times \left\{ \frac{\text{MT} \times \text{Output}}{\text{PHL}} \times 1.2 \right\}$$

(1) 0.1 - 1.00

Where:

Output = (kW) Cooling Duty, Output kW, refer to **Performance Data**, on page 19
 SHC = (kJ/kg°C) Specific Heat Capacity, 3.9 based on 20% ethylene glycol concentration.
 ΔT = (°C) Difference of Entering Water and Leaving Water temperature
 MT = Minimum Turndown
 PHL = (kW) Customer Permanent Heat Load

Example

Model Ref. = **LCC40**
 Ambient: = 35°C
 Fluid = 20% Ethylene Glycol
 Inlet Fluid Temp. = 7°C
 Outlet Fluid Temp. = 12°C (5°C ΔT)
 Customer Permanent Head Load = 20.0 kW
 Output at given conditions = 33.7 kW

$$V_m = \left\{ \frac{33.7 \times 60}{3.9 \times 5} \right\} \times 2 \times \left\{ \frac{0.10 \times 33.7}{20} \times 1.2 \right\}$$

Vm = 41.9 L

METHOD 2

Where the system permanent heat load is unknown:

$$V_m (l) = \frac{\text{Water Flow Rate (l/hour)} \times \text{Minimum Turndown Ratio} \times 1.2}{\text{Maximum Number of Compressor Starts (per Hour)}}$$

$$V_m (l) = \frac{\left\{ \frac{\text{Output} \times 60}{\text{SHC} \times \Delta T} \right\} \times \left\{ \frac{\text{Output}}{\text{PHL}} \times 1.2 \right\}}{10}$$

Example

Model Ref. = **LCC40**
 Ambient: = 35°C
 Fluid = 20% Ethylene Glycol
 Inlet Fluid Temp. = 7°C
 Outlet Fluid Temp. = 12°C (5°C ΔT)
 Output at given conditions = 33.7 kW

$$V_m = \frac{\left\{ \frac{33.7 \times 3600}{3.9 \times 5} \right\} \times \left\{ 0.1 \times 1.2 \right\}}{10}$$

Vm = 74.7 L

AIRETRONIX Controls Standard features

General Description

The microprocessor controller shall offer powerful analogue and digital control to meet a wide range of monitoring and control features including a real time clock and Industry standard communication port and network connections.

The controller's inbuilt display shall be used for viewing the unit operating status and making adjustments to control parameters by allowing the operator access to a series of display pages.

Also featured shall be a visual alarm and the facility to adjust and display control settings by local operator for information and control.

Display/keypad

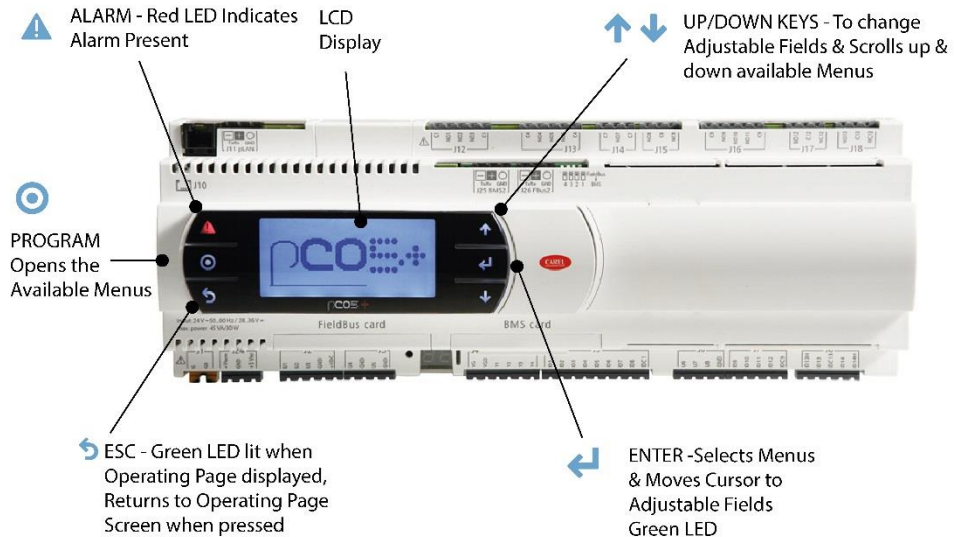

- 1 UP/DOWN KEYS - To change Adjustable Fields & Scrolls up & down available Menus
- 2 ENTER -Selects Menus & Moves Cursor to Adjustable Fields Green LED
- 3 ESC - Green LED lit when Operating Page displayed, Returns to Operating Page Screen when pressed
- 4 PROGRAM - Opens the Available Menus
- 5 ALARM - Red LED Indicates Alarm Present
- 6 LCD DISPLAY



Display content for illustration only

AIRETronix Controls

STANDARD FEATURES

Unit Remote ON/OFF	Disables/Enables the chiller remotely.
Compressor Anti Cycle Control	Automatic via the Microprocessor.
Compressor Load Limit	Limits the condensing pressure by unloading above 35 Barg. Limits the evaporating pressure by unloading at the minimum pressure setpoint, which is adjustable depending on system glycol content.
Pump(s) Remote ON/OFF	Disables/Enables the pump(s) remotely.
Remote Setback Temperature Setpoint Switch	A setback setpoint for supply water temperature can be selected to suit summer/winter conditions or night setback.
Compressor Hours Run	Displays hours run of each compressor.
Password Protection	The control system integrity can be maintained by restricting access with a password PIN number.

CAUTION  **IMPORTANT: To change the PIN number; please contact Airedale at time of order with the preferred 4 digit number.**

OPTIONAL FEATURES

Pump(s) Hours Run	Displays hours run of each pump.
BMS Interface Card	Enables AIRETronix Controlled units to be interfaced with most BMS, factory fitted, please contact Airedale. A wide range of protocols can be accommodated through the use of interface devices. Available as a standard option are: ModBus/Jbus, Carel and Trend. For interfaces such as SNMP, LonWorks, Metasys and BACnet, please contact Airedale. Also available is Airedale's own supervisory plug-in BMS card pCOWEB. Based on Ethernet TCP/IP secure technology with SNMP features. Requires no proprietary cabling or monitoring software and supplied pre programmed with an IP address for ease of set up.
GSM Modem Kit	Allows remote alarm monitoring by sending alarm text messages to a nominated mobile phone, factory set.

AIRETRONIX Controls

TEMPERATURE CONTROL

The unit has been designed to provide the cooling load required whilst optimising energy efficiency **at all times** and as such will take advantage of **free cooling** whenever available. If the free cooling available cannot satisfy the required full cooling load, DX mechanical cooling is used to supplement the output.

Airedale recognises that all chiller applications are different but fall mainly into 2 application categories; Variable Supply Temperature and Constant Supply Temperature.

The onboard microprocessor has the capability of satisfying either control requirement using the Airedale Variable Supply Temperature control scheme; energy savings are available when compared with previous schemes and that of the Constant Supply Temperature application.

Variable Supply Temperature control schemes offer energy savings where the supply water temperature is not critical to its operation. By monitoring the temperatures of the return and supply water the units cooling capacity is adjusted through use of the microprocessor controls to maintain an average temperature set point between the supply and return temperatures.

Selection of the best application control scheme can be made via a soft switch in the microprocessor during initial commissioning.

CAUTION  **Factory set to Variable Supply Temperature Control unless otherwise stated at order.**

Only when the mode selection has been set can the unit be enabled.

FreeCooling Operation

In high ambients where free-cooling is not available the fan speed modulates in the conventional manner to maintain a constant head pressure. Free cooling is initiated wherever the outdoor ambient is 1°C less than the return water temperature.

When free cooling and DX (mechanical) cooling are operating simultaneously the condenser fan speed will operate at 100% maximising free cooling.

In ambients where the free cooling coil is capable of satisfying the full cooling demand, the condenser fans are modulated to provide the desired duty. The condenser fans are capable of being modulated between 25-100% of airflow to maintain the supply water temperature.

During periods where the condenser fan speed has been reduced to a minimum, the supply water temperature will then be controlled by the 3 way valve.

AIRETronix Controls

MONITORING

The microprocessor also monitors and displays the following measured parameters:

- Supply Water Temperature
- Return Water Temperature
- Evaporator Inlet water temperature
- Ambient Air Temperature
- Suction Pressure
- Liquid Pressure
- Evaporator Waterside Differential Pressure
- Evaporator Waterside Flow Rate (calculated)

ALARM HANDLING

The following conditions will be detected, triggering a visual alarm:

- Low Supply Temperature
- Mains Phase Failure / Phase Rotation
- Emergency Stop (Option)
- Water Flow
- Pump(s) status
- Individual Compressor Trip
- Low Suction Pressure
- High Liquid Pressure
- Low Pressure Switch
- Individual Compressor Overload
- Isolator Status
- Individual High Compressor Discharge Temperature
- Volt Free Contact Non-Critical Alarm Indication
- Volt Free Contact Critical Alarm Indication

Performance Data

ESEER CALCULATIONS The quoted EER figures (*General Specification*, on page 28) cover the performance of the unit ONLY at the standard rating conditions of 7/12°C water, 35°C ambient. The ESEER calculation method has been developed by Eurovent to give a single value that is a realistic indication of the efficiency of the chiller across the whole range of operation.

The ESEER value is calculated from the unit's performance at 20, 25, 30 and 35°C ambient temperatures for all loading stages, and with a fixed 7°C supply temperature. All calculations assume the system operates with 100% water.

$$ESEER = A.EER_{100\%} + B.EER_{75\%} + C.EER_{50\%} + D.EER_{25\%}$$

A, B, C and D are weighting factors 0.03, 0.33, 0.41 and 0.25.

Temperature	20°C	25°C	30°C	35°C
Capacity Requirement	25%	50%	75%	100%
Percentage of Total Hours	0.25	0.41	0.33	0.03

FSEER CALCULATIONS (Free Cooling) Whilst the ESEER is useful for providing a true energy efficiency of a unit's performance over a year it does not offer any advantages for use of free-cooling which can significantly reduce the unit's lifecycle power consumption.

The FSEER calculation method has been developed by Airedale to give a single value that is a realistic indication of the efficiency of the chiller across the whole range of operation.

The quoted Airedale FSEER figures (*General Specification*, on page 28) are similar to the ESEER and includes the unit's free cooling capacity within the calculation. All calculations for the FSEER use water with 20% ethylene glycol content. Flow rates are kept constant for all conditions and are determined by the operation at 7/12°C, 35°C ambient.

Free cooling capacity is included within the units EER when available. DX cooling capacity is included within the Chillers EER when the Free-cooling available is not sufficient to satisfy the total cooling demand.

$$ESEER = A.EER_{100\%} + B.EER_{75\%} + C.EER_{50\%} + D.EER_{25\%}$$

A, B, C and D are weighting factors 0.05, 0.25, 0.47, 0.23.

Temperature	0°C	10°C	20°C	30°C
Capacity Requirement	0.25	0.5	0.75	1
Percentage of Total Hours	0.23	0.47	0.25	0.05

Performance Data

CAPACITY DATA - DX (MECHANICAL) COOLING

Cooling Duty	Entering / Leaving Water Temperature °C	Ambient							
		25°C		30°C		35°C		40°C	
		Output kW	Input kW	Output kW	Input kW	Output kW	Input kW	Output kW	Input kW
LCC20	10 / 5	18.7	6.0	18.1	6.4	17.1	7.0	16.2	7.5
	11 / 6	19.3	6.0	18.7	6.4	17.7	7.0	16.8	7.6
	12 / 7	19.9	6.0	19.2	6.4	18.2	7.1	17.3	7.6
	15 / 10	21.8	6.1	21.0	6.6	19.8	7.2	18.8	7.7
	17 / 12	23.2	6.1	22.2	6.6	21.0	7.2	19.9	7.8
LCC40	10 / 5	35.6	11.8	33.6	13.0	31.8	14.2	29.9	15.3
	11 / 6	36.6	11.9	34.7	13.1	32.8	14.3	30.9	15.4
	12 / 7	37.7	12.0	35.7	13.2	33.7	14.4	31.8	15.5
	15 / 10	40.9	12.4	38.8	13.5	36.7	14.7	34.7	15.9
	17 / 12	43.2	12.6	40.9	13.8	38.8	14.9	36.7	16.1

1 Cooling Duty based on 20% Ethylene Glycol concentration. For alternative concentrations, refer to **Glycol Data**, on page 22.

2 Output kW = DX (Mechanical) Cooling duty.

3 Input kW = compressor + fan input power.

4 Unit water flow rate (l/s) =
$$\frac{\text{Output kW}}{3.9 \times \Delta T}$$

5 Interpolate for water temperatures between those quoted, do not extrapolate.

6 For conditions outside those quoted, please refer to Airedale.

OPERATING LIMITS (For 20% Ethylene Glycol)

Standard Unit	
Minimum Ambient Air DB °C	-20°C
Maximum Ambient Air DB °C	Refer to Capacity Data - DX (Mechanical) Cooling , above
Minimum Leaving Water Temperature °C	+5°C
Maximum Return Water Temperature °C	+20°C
Minimum / Maximum ΔT	4°C / 8°C

1 For conditions outside those quoted, please refer to Airedale.
All performance data is supplied in accordance with BS EN 14511-1:2013

Performance Data

CAPACITY DATA - FREE COOLING

Determine the Free Cooling capacity as follows using the graphs provided:

Example	Model Ref.	= LCC40
	Ambient:	= 35°C
	Fluid	= 20% Ethylene Glycol
	Inlet Fluid Temp.	= 7°C
	Outlet Fluid Temp.	= 12°C (5°C ΔT)
	Customer Permanent Head Load	= 20 kW

Calculate Waterflow l/s

$$\text{Flow} = \left\{ \frac{\text{Output}}{3.9 \times \Delta T} \right\}$$

$$\text{Flow} = \left\{ \frac{33.7}{3.9 \times 5} \right\}$$

$$\text{Flow} = \mathbf{1.73 \text{ l/s}}$$

Select Free Cooling Curve

$$\Delta T_{FC} (\text{°C}) = \left\{ \text{Return Water Temp} - \text{Ambient Temp} \right\}$$

$$\Delta T_{FC} (\text{°C}) = \left\{ \begin{array}{c} 15 - 5 \end{array} \right\}$$

$$\Delta T_{FC} (\text{°C}) = \mathbf{10\text{°C}}$$

Free Cooling (kW)

As plotted on graph = **30kW**

Where:

Output = (kW) Cooling Duty, Output kW, refer to **Capacity Data - DX (Mechanical) Cooling**, on page 19

ΔT = (°C) Difference of Entering Water and Leaving Water temperature

ΔT_{FC} = (°C) Difference of Leaving Water temperature and Ambient temperature

All performance data is supplied in accordance with BS EN 14511-1:2013

Performance Data

CAPACITY DATA - FREE COOLING

LCC20

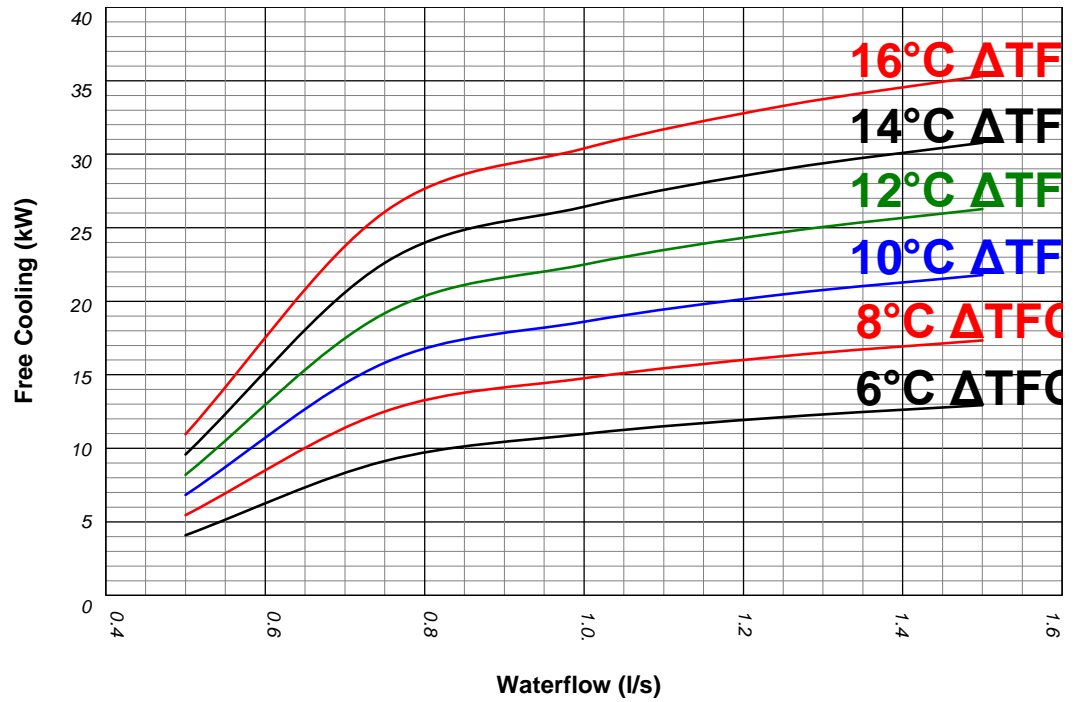

LCC40

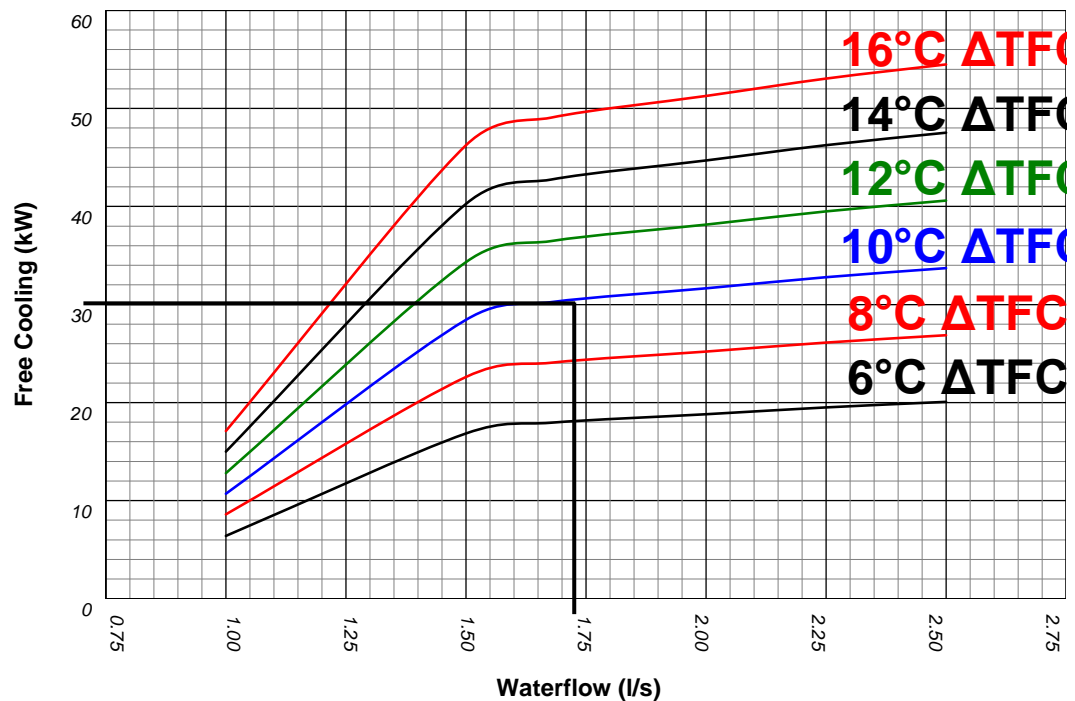

All performance data is supplied in accordance with BS EN 14511-1:2013

Performance Data

GLYCOL DATA

For a given percentage of glycol in the system there are correction factors that need to be applied, the following tables can be used as a guide.

CAUTION  All free-cooling units should use a **MINIMUM 20% glycol concentration**.

Ethylene Glycol Nominal Correction Factors

Glycol in System / Freezing Point °C		20% / -9°C	30% / -15°C	40% / -23°C
Output (kW)	x	1.00	0.98	0.96
Input (kW)		1.00	0.98	0.97
Water Flow (l/s)		1.00	1.09	1.12
Pressure Drop (kPa)		1.00	1.29	1.48

Propylene Glycol Nominal Correction Factors

Glycol in System / Freezing Point °C		20% / -6°C	30% / -12°C	40% / -20°C
Output (kW)	x	0.98	0.94	0.91
Input (kW)		1.00	0.98	0.97
Water Flow (l/s)		1.00	0.99	0.99
Pressure Drop (kPa)		1.08	1.22	1.35

Example

Model Ref. = **LCC40**
 Ambient: = 35°C
 Fluid = 30% Ethylene Glycol
 Inlet Fluid Temp. = 7°C
 Outlet Fluid Temp. = 12°C (5°C ΔT)

		Catalogue	Multiplier	Corrected Figure	
Output (kW)	=	33.7	x 0.98	= 33.0 kW	
Compressor Input (kW)		14.4	x 0.98	= 14.1 kW	
Water Flow (l/s)		$\left\{ \frac{\text{Output}}{3.9 \times \Delta T} \right\}$	1.99	x 1.02	= 2.03 l/s
Pressure Drop (kPa)		Plot from curve (refer to Waterside Pressure Drop (kPa) , on page 23)	128	x 1.15	= 147.2 kPa

Where:

Output = (kW) Output kW, refer to **Capacity Data - DX (Mechanical) Cooling**, on page 19
 Input = (kW) Input kW, refer to **Capacity Data - DX (Mechanical) Cooling**, on page 19
 ΔT = (°C) Difference of Entering Water and Leaving Water temperature

Performance Data

WATERSIDE PRESSURE DROP (KPA)

CAUTION ▼ Full design water flow **MUST** be maintained at all times. Variable water volume is **NOT** recommended and will invalidate warranty

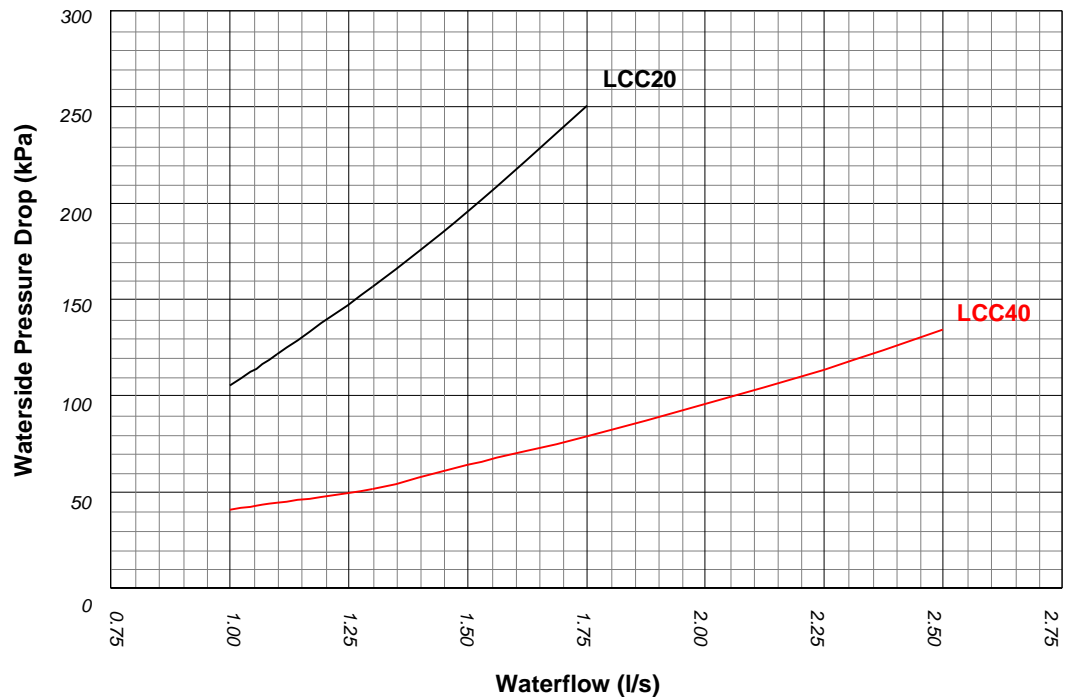

- (1) For glycol solutions, please refer to **Glycol Data**, on page 22.
- (2) Chiller pressure drop refers to standard unit.
All performance data is supplied in accordance with BS EN 14511-1:2013

Performance Data

PUMP PACKAGES (OPTIONAL EXTRAS)

Use the formula below and the graphs provided to calculate the External Head Available:

Example:

Model Ref. = **LCC40**
 Ambient: = 35°C
 Fluid = 20% Ethylene Glycol
 Inlet Fluid = 7°C
 Outlet Fluid = 12°C (**5°C ΔT**)
 Pump Selection = Single Standard
 Water Flow l/s = 1.87 l/s

$$\begin{aligned}
 \text{EHA (kPa)} &= \text{External Head Available} \\
 \text{EHA (kPa)} &= \left\{ \begin{array}{c} \text{Total Pump Head Available} \\ - \\ \text{Unit Waterside Pressure Drop} \end{array} \right\} \\
 \text{EHA (kPa)} &= \left\{ \begin{array}{c} 165 - 82 \end{array} \right\} \\
 \text{EHA (kPa)} &= \underline{\underline{\mathbf{83 \text{ kPa}}}}
 \end{aligned}$$

Performance Data

PUMP PACKAGES (OPTIONAL EXTRAS)

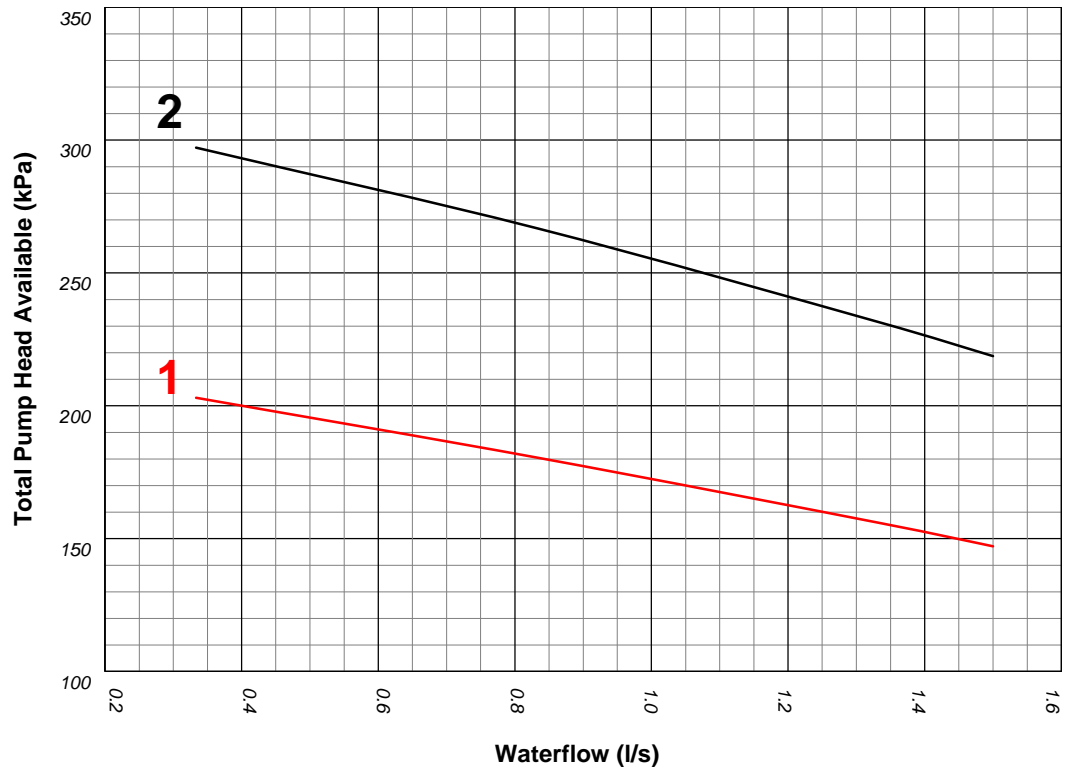

		Single Head Pump or Run / Standby Pump	
		Standard	Larger
LCC20	Curve	1	2
LCC40	Curve	3	4

Sound Data

MEASUREMENT OF SOUND DATA

All sound data quoted has been measured in the third-octave band limited values, using a Real Time Analyser calibrated sound intensity meter in accordance with BS EN ISO9614 Part 1 : 2009. **The Global sound data quoted is valid for noise emitted in the horizontal plane in all directions**

All Sound Power Levels quoted are calculated from measured sound intensity according to BS EN ISO9614 Part 1: 2009.

Sound Pressure Levels are calculated from sound power using the expanded parallelepiped method according to BS EN ISO11203: 2009.

SOUND DIRECTIVITY

The **Global** sound measurements quoted in the following tables **do not** incorporate any directivity or denote any sound level heard at any given position surrounding the chiller, rather they represent the total sound level radiating from the chiller in **all directions in the horizontal plane** from source.

Sound Data

SOUND DATA

Global Chiller Sound Level Values

	Sound Measurement	Overall dB(A)	Frequency (Hz) dB						
			63	125	250	500	1000	2000	4000
LCC20	Power	85	82	86	82	78	80	79	74
	Pressure @ 10m	53	50	54	50	46	48	47	42
LCC40	Power	86	83	86	86	82	81	78	72
	Pressure @ 10m	54	52	55	54	50	49	46	40

- 1 dB(A) is the overall sound level, measured on the A scale.
- 2 All sound data measured at nominal conditions: Water in/out 12/7°C at 35°C ambient.
- 3 Based on standard unit, for units fitted with optional pump packages, please contact Airedale.



The Sound Pressure data quoted is only valid in free field conditions, where the unit is installed on a reflective base. If the equipment is placed adjacent to a reflective wall, values may vary to those stated, typically increasing by 3dB for each side added.

General Specification

MECHANICAL DATA

			LCC20	LCC40
Capacity				
Nom Output - Cooling - DX (Mechanical)	(1)	kW	18.2	33.7
Nom Input - Cooling DX (Mechanical)	(1)	kW	7.1	14.4
EER - DX (Mechanical)	(2)		2.56	2.34
ESEER	(3)		2.5	3.0
FSEER	(4)		3.4	4.2
Nom Cooling - Free Cooling	(5)	kW	12.0	21.0
Capacity Steps		%	0, 20 - 100	0, 10 - 100
Dimensions - H x W x L			2060 x 1160 x 1290	2230 x 1370 x 1400
Weight				
Machine	(6)	kg	530	620
Operating	(6)	kg	540	635
Construction			Base: Plain Galvanised Steel	
Material / Colour			Panels: Galvanised Sheet Steel, Epoxy Baked Powder Paint - Light Grey, (RAL 7035)	
Evaporator			Stainless Steel Brazed Plate	
Insulation			Class 1 / UV Stable	
Water Volume		l	1.5	3.0
Total Max. Water Flow		l/s	1.1	2.4
Condenser			Copper Tube/ Aluminium Fins	
Face Area (Total)		m ²	1.23	1.75
Nominal Airflow		m ³ /s	3.30	4.40
Fan & Motor			Axial - Sickle Bladed Fan	
Quantity			1	1
Diameter		mm	710	800
Maximum Speed		rpm	900	1100
Compressor			Single	Tandem
Type			Digital Scroll	1 Digital + 1 Standard Scroll
Quantity			1	2
Oil Charge Volume (Total)		l	1.69	1.69
Oil Type			Polyol Ester	
Refrigeration			Single Circuit	
Refrigerant Control			Electronic Expansion Valve (EEV)	
Refrigerant Type - Precharged			R410A	
Charge (Total)		kg	6.8	10.3
Connections				
Water Inlet / Outlet - Type			PN16	PN16
Water Inlet / Outlet - Size		in	1 1/4	1 1/2
Water Drain/Bleed		in	1/2	1/2
Water System				
Min. System Water Volume	(7)	l	80.6	74.7
Max. System Press		bar	10	10
OPTIONAL EXTRAS				
Water Pump			In Line Pump	
Max. System Press		bar	7	7
Nom. External Head:				
Single / Run & Standby - Standard		kPa	85	87
Single / Run & Standby - Larger		kPa	169	162
Expansion Vessel				
Water Capacity		l	8	12

(1) Based on 12/7°C water temperature and 35°C ambient with a 20% Ethylene Glycol Water Concentration.

(2) $EER = \frac{\text{Output kW}}{\text{Input kW}}$ Where: Output kW = DX (Mechanical) Cooling duty.
 Input kW = Compressor + fan input power.

(3) ESEER, refer to **Performance Data**, ESEER Calculations on page 18.

(4) FSEER, refer to **Performance Data**, ESEER Calculations on page 18.

(5) Free Cooling duties based on flow rate at conditions (1), 12°C return water temperature @ 5°C ambient and 20% Ethylene Glycol Water Concentration.

(6) Based on standard unit, for units fitted with options, please contact Airedale.

(7) For minimum system volume, refer to **Minimum System Water Volume Calculations**, on page 13.

All performance data is supplied in accordance with BS EN 14511-1:2013

General Specification

ELECTRICAL DATA

			LCC20	LCC40
Unit Data				
Nominal Run Amps	(1)	A	14	28
Maximum Start Amps	(2)	A	103	117
Permanent Supply		VAC	230 V 1 PH 50 Hz	
Mains Supply		VAC	400 V 3 PH 50 Hz	
Rec Permanent Fuse Size		A	16	16
Rec Mains Fuse Size		A	25	40
Max Permanent Incoming Cable Size		mm ²	4 mm ² terminals	
Max Mains Incoming Cable Size		mm ²	35 (Direct to Isolator)	
Control Circuit		VAC	24V/230VAC	
Evaporator				
Pad Heater Rating		W	25	25
External Trace Heating				
Available (fitted by others)		W	500	500
AC Condenser Fan - Per Fan				
Quantity			1	1
Motor Size		kW	0.98	1.80
Full Load Amps		A	1.75	3.80
Locked Rotor Amps		A	6.20	11.00
Compressor - Per Compressor				
Quantity			1	1 + 1
Motor Size		kW	6.8	6.8 / 6.4
Nominal Run Amps	(1)	A	12.1	12.1 / 11.7
Start Amps	(2)	A	101	101 / 101
Type Of Start			Direct on line	
OPTIONAL EXTRAS				
Compressor Oil Heater Rating		W	70	70 / 70
Electronic Soft-start				
Nominal Run Amps	(1)	A	14	28
Maximum Start Amps		A	63	77
Recommended Mains Fuse		A	25	40
EC Condenser Fan - Per Fan				
Quantity			1	1
Full Load Amps		A	3.10	4.10
Motor Size		kW	1.85	2.60
Water Pump				
Single Head or Run/Standby - Standard				
Unit Nominal Run Amps	(1)	A	15	30
Recommended Mains Fuse		A	25	40
Motor Size		kW	0.37	0.50
Full Load Amps		A	1.40	1.90
Single Head or Run/Standby - Larger				
Unit Nominal Run Amps	(1)	A	16	31
Recommended Mains Fuse		A	25	40
Motor Size		kW	0.75	0.90
Full Load Amps		A	2.30	3.00

(1) To ARI standard conditions ARI 540 (7.2°C evaporating; 54.4°C condensing).

(2) Starting amps refers to the direct on line connections.

Dimensional Data

DIMENSIONS

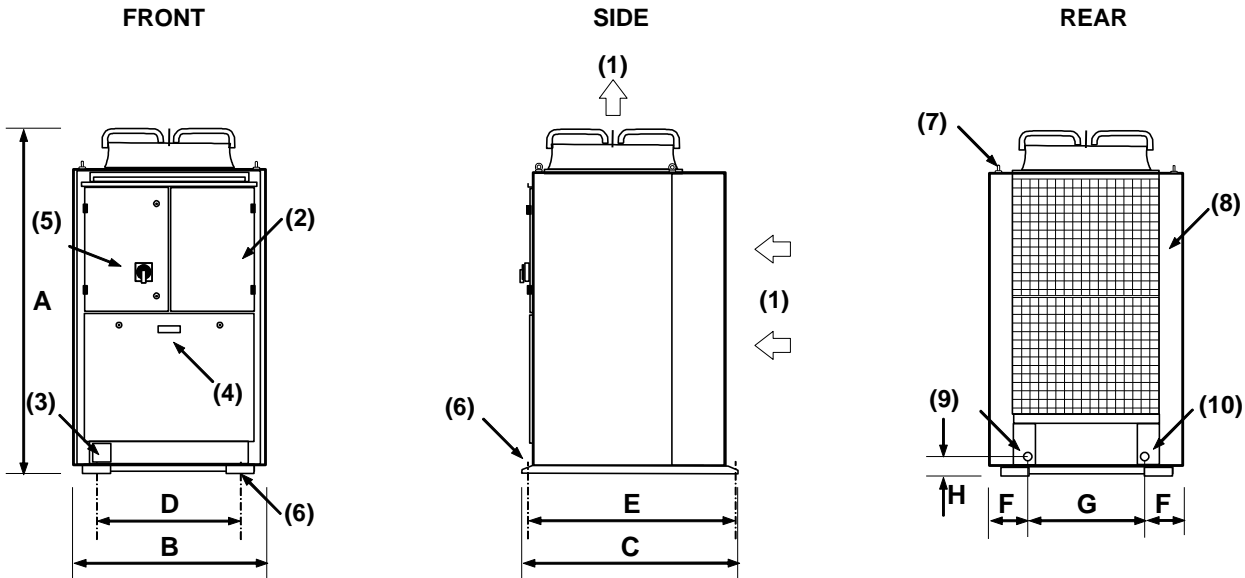

		A	B	C	D (8)	E (8)	F	G	H
LCC20	mm	2063	1160	1286	867	1246	223	713	94
LCC40	mm	2227	1280	1406	987	1367	363	554	40

Unit diagrams can be supplied on request, please contact Airedale.

- (1) Airflow direction.
 - (2) Electric control panel.
 - (3) Mains cable entry.
 - (4) Compressor compartment.
 - (5) Mains electric isolator.
 - (6) 1/2 BSP Ø mounting holes.
 - (7) Lifting eye bolts x 4.
 - (8) Refrigeration component access panels.
 - (9) Water Outlet
 - (10) Water Inlet
- } BSP Female Connection: LCC20 1 1/4"
LCC40 1 1/2"

(Note:- the pipework connections on the unit allow for a 1 1/2" BSP Male fitting to be screwed into the assembly).

WEIGHTS

		Machine	Operating
LCC20	kg	530	540
LCC40	kg	620	635

- (1) Based on standard unit, for units fitted options, please contact Airedale.

Installation Data

UNIT LIFTING

- Employ lifting specialists
- Local codes and regulations relating to the lifting of this type of equipment should be observed
- Use the lifting eye bolts/lifting lugs provided
- Attach lifting chains to the 4 lifting eye bolts/lifting lugs provided; each chain and eye bolt must be capable of lifting the whole chiller
- Use the appropriate spreader bars/lifting slings with the holes/lugs provided
- Chains/slugs **MUST NOT** interfere with the casing of fan assembly to avoid damage
- Lift the unit slowly and evenly
- If the unit is dropped, it should immediately be checked for damage and reported to Airedale

CAUTION  **Only use lifting points provided.**

The unit should be lifted from the top and where possible, with all packing and protection in position. If any other type of slinging is used, due care should be taken to ensure that the slings do not crush the casework or coil.

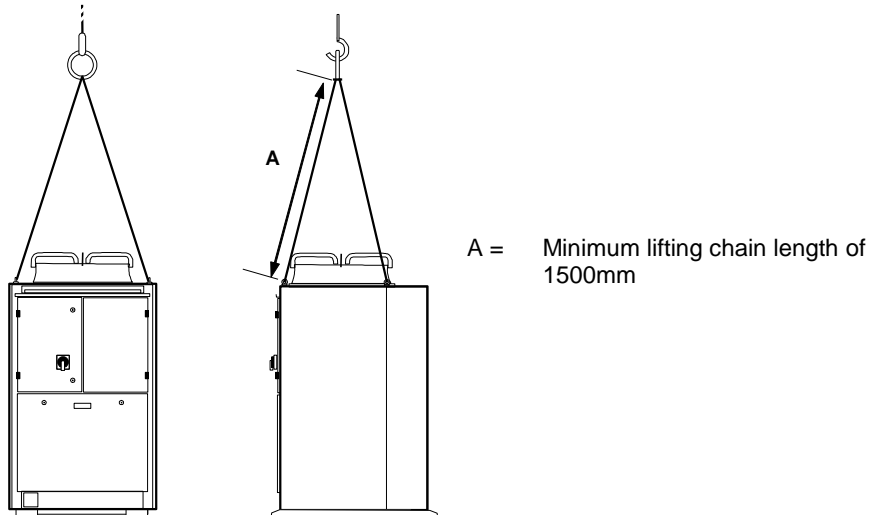

Installation Data

POSITIONING

- The installation position should be selected with the following points in mind:
- Position on a stable and even base, levelled to ensure that the compressor operates correctly
 - Levelling should be to +/- 5mm
 - Where vibration transmission to the building structure is possible, fit pad anti-vibration mounts and flexible water connections
 - Observe airflow and maintenance clearances
 - Pipework and electrical connections are readily accessible
 - Where multiple units are installed, due care should be taken to avoid the discharge air from each unit adversely affecting other units in the vicinity
 - Within a side enclosed installation, the fan MUST be higher than the enclosing structure
 - Multiply x 2 airflow clearance for 3 side enclosed applications
 - Ensure there are no obstructions directly above the fans
 - Allow free space above the fans to prevent air recirculation

CAUTION ▼ Prior to connecting services, ensure that the equipment is installed and completely level.

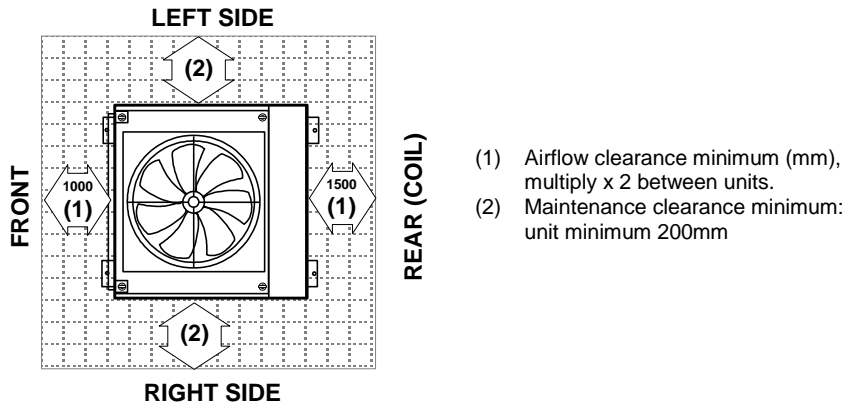

WATER SYSTEM

- Chilled water pipework and ancillary components must be installed in accordance with:
- National and Local Water supply company standards
 - The manufacturer's instructions are followed when fitting ancillary components
 - The system liquid is treated to prevent corrosion and algae forming
 - Glycol required as standard, with the correct concentration to suit the lowest ambient the equipment will experience
 - The schematic is referred to as a guide to ancillary recommendations

CAUTION ▼ The unit water connections are NOT designed to support external pipework, pipework MUST be supported separately.

Installation Data

STANDARD RECOMMENDED INSTALLATION (Parts Supplied by Others)

General

Airedale offers a wide range of optional extras to suit various applications including integral pump, please refer to **Optional Extras - General**, on page 8 for details.

CAUTION ⚠ **Should non Airedale parts be used, the following installation recommendations should be adhered to. Failure to do this will invalidate the chiller warranty.**

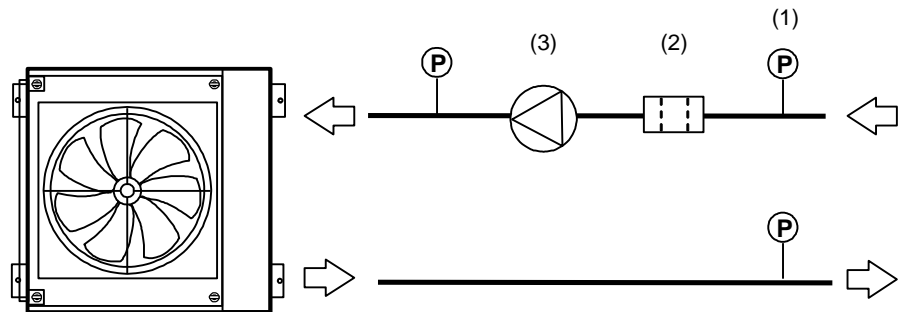

- (1) Pressure Sensors
- (2) Filter 1 1/16 BSP
- (3) Pump

CAUTION ⚠ **Full design water flow MUST be maintained at all times. Variable water volume is NOT recommended and will invalidate warranty**

CAUTION ⚠ **The correct operation of the flow proving device is critical if the chiller warranty is to be valid.**

CAUTION ⚠ **Following components are fitted within the chiller unit as standard:**

- Temperature Sensors
- Drain Point
- Auto Air Vent
- Differential Pressure Monitoring of Evaporator
- Pressure Sensing Points
- 20 Mesh Inlet Filter

Component Recommended Requirements

The recommended requirements to allow commissioning to be carried out correctly are:

- The inclusion of Binder Points adjacent to the flow and return connections, to allow temperature and pressure readings
- A flow switch or equivalent, fitted adjacent to the water outlet side of the unit Chiller
- A water-flow commissioning valve set fitted to the system
- In multiple chiller installations, 1 commissioning valve set is required per chiller
- Isolating valves should be installed adjacent to all major items of equipment for ease of maintenance
- Balancing valves can be installed if required to aid correct system balancing
- All chilled water pipework must be insulated and vapour sealed to avoid condensation
- If several units are installed in parallel adjacent to each other, reverse return should be applied to avoid unnecessary balancing valves

Installation Data

PUMPS

Pump Statement

When installing circulating water pumps or equipment containing them, the following rules should be applied:

- Ensure the system is filled with liquid then vented and the pump primed with water before running the pump, this is required because the pumped liquid cools the pump bearings and mechanical seal faces
- To avoid cavitation the NPSH (Net Positive Suction Head) incorporating a safety margin of 0.5m head must be available at the pump inlet during operation

PUMP PACKAGES (OPTIONAL EXTRAS)

Flow Schemes:

- A Standard Unit - No Pump
- B Single Head Pump
- C Run/Standby Pump

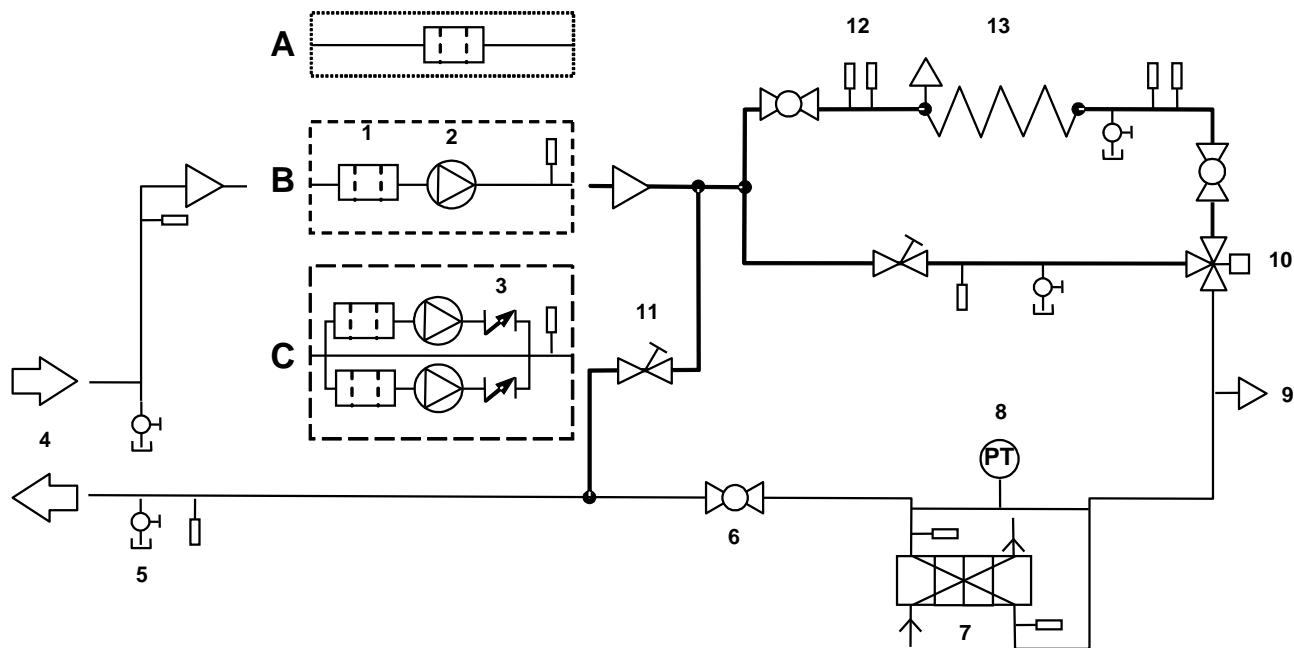

- | | |
|-------------------------|------------------------------------|
| 1 Filter Ball Valve | 8 Differential Pressure Transducer |
| 2 Pump | 9 Auto Air Vent |
| 3 Non Return Valve | 10 Mixing Valve |
| 4 Water Supply & Return | 11 DRV (Flushing Bypass) |
| 5 Drain | 12 Binder Points |
| 6 Ball Valve | 13 Free Cooling Coil |
| 7 Plate Evaporator | |

Interlocks & Protection

Always electrically interlock the operation of the chiller with the pump controls for safety reasons.

CAUTION Failure to will invalidate the chiller warranty.

CAUTION Do not rely solely on the BMS to protect the chiller against low flow conditions.

An evaporator pump interlock **MUST** be directly wired to the chiller, to Interconnecting Wiring, on page 35.

Installation Data

ELECTRICAL

CAUTION ⚠ ALL work **MUST** be carried out by technically trained competent personnel.

⚠ The equipment contains live electrical and moving parts, **ISOLATE** prior to maintenance or repair work.

General

- As standard the equipment is designed for 400V, 3 phase, 3 wire 50Hz and a separate permanent 230V, 1 phase, 50Hz supply, to all relevant IEE regulations, British standards and IEC requirements
- The control voltage to the interlocks is 24V, always size the low voltage interlock and protection cabling for a maximum voltage drop of 2V
- Avoid large voltage drops on cable runs, particularly low voltage wiring

CAUTION ⚠ A fused and isolated electrical supply of the appropriate phase, frequency and voltage should be installed.

Wires should be capable of carrying the maximum load current under non-fault conditions at the stipulated voltage.

A separately fused, locally isolated, permanent single phase and neutral supply **MUST BE FITTED** for the compressor oil heater (if fitted), evaporator trace heating and control circuits, **FAILURE to do so could INVALIDATE WARRANTY.**

Interlocks & Protection

Always electrically interlock the operation of the chiller with the pump controls for safety reasons.

CAUTION ⚠ Do not rely solely on the BMS to protect the chiller against low flow conditions.

If a pump package is not selected as part of the unit, an evaporator pump interlock **MUST** be directly wired to the chiller, to Interconnecting Wiring diagram. Failure to comply will invalidate the chiller warranty.

INTERCONNECTING WIRING

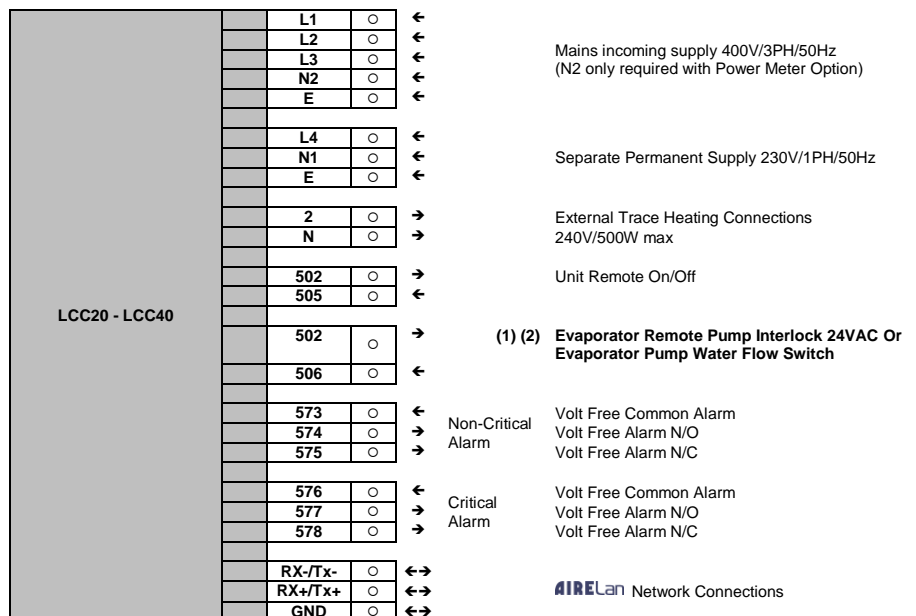

CAUTION ⚠ (1) **MUST** be directly wired to the chiller to validate warranty.
(2) Not required with integral pump package fitted.

pLAN Termination

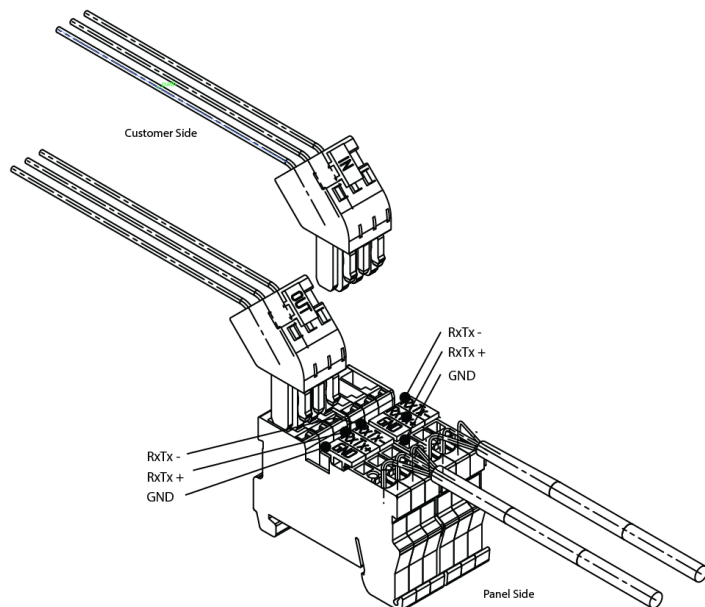

IMPORTANT: The plugged termination ensures that the connections are made simultaneously. Failure to attach the cables this way may cause damage to the controller.



Head Office:

Airedale International Air Conditioning Ltd
Leeds Road
Rawdon
Leeds LS19 6JY
United Kingdom

Tel: +44 (0) 113 239 1000
Fax: +44 (0) 113 250 7219

e-mail: enquiries@airedale.com
website: www.airedale.com

A MODINE Company

PART NO:	ISSUE	DATE
6521355	A	01/05/07
	B	01/06/07
	C	01/10/07
	D	01/06/09
	E	13/04/2010
	F	04/2014
	G	09/2012
	V1.7.0	02-2013
	V1.8.0	07/2014
	V1.9.0	10/2014
	V1.9.1	10/2015
	V1.10.0	03/2016
	V1.11.0	04/2016
	V1.12.0	05/2016
	1.13.0	08/2016
	1.14.0	11/2016