

**Condensers**  
C11HI-C45HI  
11-45 kW  
CS50-CS105  
50-105kW



**TECHNICAL MANUAL**



FM00542

EMS52086

## Warranty, Commissioning & Maintenance

As standard, Airedale guarantees all non consumable parts only for a period of 12 months, variations tailored to suit product and application are also available; please contact Airedale for full terms and details. To further protect your investment in Airedale products, Airedale can provide full commissioning services, comprehensive maintenance packages and service cover 24 hours a day, 365 days a year (UK mainland). For a free quotation contact Airedale or your local Sales Engineer.

All Airedale products are designed in accordance with EU Directives regarding prevention of build up of water, associated with the risk of contaminants such as Legionella.

For effective prevention of such risk it is necessary that the equipment is maintained in accordance with Airedale recommendations.

### SafeCool™

In addition to commissioning, a 24 hour, 7 days a week on-call service is available throughout the year to UK mainland sites. This service will enable customers to contact a duty engineer outside normal working hours and receive assistance over the telephone. The duty engineer can, if necessary, attend site, usually within 24 hours or less.

Full details will be forwarded on acceptance of the maintenance agreement.

#### CAUTION ⚠

Warranty cover is not a substitute for maintenance. Warranty cover is conditional to maintenance being carried out in accordance with the recommendations provided during the warranty period. Failure to have the maintenance procedures carried out will invalidate the warranty and any liabilities by Airedale International Air Conditioning Ltd.

## Spares

A spares list for 1, 3 and 5 years will be supplied with every unit and is also available from our Spares department on request.

## Training

As well as our comprehensive range of products, Airedale offers a modular range of Refrigeration and Air Conditioning Training courses, for further information please contact Airedale.

## Customer Services

For further assistance, please e-mail: [connect@airedale.com](mailto:connect@airedale.com) or telephone:

UK Sales Enquiries	+ 44 (0) 113 239 1000	<a href="mailto:connect@airedale.com">connect@airedale.com</a>
International Enquiries	+ 44 (0) 113 239 1000	<a href="mailto:connect@airedale.com">connect@airedale.com</a>
Spares Hot Line	+ 44 (0) 113 238 7878	<a href="mailto:spares@airedale.com">spares@airedale.com</a>
Airedale Service	+ 44 (0) 113 239 1000	<a href="mailto:service@airedale.com">service@airedale.com</a>
Technical Support	+ 44 (0) 113 239 1000	<a href="mailto:tech.support@airedale.com">tech.support@airedale.com</a>
Training Enquiries	+ 44 (0) 113 239 1000	<a href="mailto:training@airedale.com">training@airedale.com</a>

For information, visit us at our Web Site: [www.airedale.com](http://www.airedale.com)

Airedale Ltd endeavours to ensure that the information in this document is correct and fairly stated, but none of the statements are to be relied upon as a statement or representation of fact. Airedale Ltd does not accept liability for any error or omission, or for any reliance placed on the information contained in this document. The development of Airedale products and services is continuous and the information in this document may not be up to date. It is important to check the current position with Airedale Ltd at the address stated. This document is not part of a contract or licence unless expressly agreed. No part of this document may be reproduced or transmitted in any form or by any means, electronic or mechanical, including photocopying, recording, or information storage and retrieval systems, for any purpose other than the purchaser's personal use, without the express written permission of Airedale Ltd.

© 2019 Airedale International Air Conditioning Limited. All rights reserved. Printed in the UK.

## Environmental Policy

It is our policy to:

- Take a proactive approach to resolve environmental issues and ensure compliance with regulatory requirements
- Train personnel in sound environmental practices
- Pursue opportunities to conserve resources, prevent pollution and eliminate waste
- Manufacture products in a responsible manner with minimum impact on the environment
- Reduce our use of chemicals and minimise their release to the environment
- Measure, control and verify environmental performance through internal and external audits
- Continually improve our environmental performance

## CE Directive

Airedale certify that the equipment detailed in this manual conforms with the following EC Directives:

Electromagnetic Compatibility Directive (EMC)	2014/30/EU
Machinery Directive (MD)	89/392/EEC version 2006/42/EC
Pressure Equipment Directive (PED)	2014/68/EU

To comply with these directives appropriate national & harmonised standards have been applied. These are listed on the Declaration of Conformity, supplied with each product.

## Health and Safety

### IMPORTANT

The information contained in this manual is critical to the correct operation and maintenance of the unit and should be read by all persons responsible for the installation, commissioning and maintenance of the Airedale unit.

### Safety

The equipment has been designed and manufactured to meet international safety standards but, like any mechanical/ electrical equipment, care must be taken if you are to obtain the best results.

<b>CAUTION</b> ⚠	<p>When working with any air conditioning units ensure that the electrical isolator is switched off prior to servicing or repair work and that there is no power to any part of the equipment.</p> <p>Also ensure that there are no other power feeds to the unit such as fire alarm circuits, BMS circuits etc.</p> <p>Electrical installation commissioning and maintenance work on this equipment should be undertaken by competent and trained personnel in accordance with local relevant standards and codes of practice.</p>
------------------	---

The refrigerant used in this range of products is classified under the COSHH regulations as an irritant, with set Workplace Exposure Levels (WEL) for consideration if this plant is installed in confined or poorly ventilated areas. A full hazard data sheet in accordance with COSHH regulations is available should this be required.

### Protective Personal Equipment

Airedale recommends that personal protective equipment is used whilst installing, maintaining and commissioning equipment.

### Refrigerant Warning

This Airedale unit uses R407C refrigerant which requires careful attention to proper storage and handling procedures. Use only manifold gauge sets designed for use with R407C refrigerant. Use only refrigerant recovery units and cylinders designed for high pressure refrigerants. R407C must only be charged in the liquid state to ensure correct blend makeup. The refrigerant must be stored in a clean, dry area away from sunlight and must never be stored above 50°C.

### Global Warming Potential

The R407C refrigerant has a GWP of 1774 (based on EN378-1:2016, 100 year life)

### Pressure Equipment Directive (2014/68/EU)

### Minimum and Maximum Operation Temperature (TS) and Pressure (PS)

### Refrigeration

Allowable Temperature Range (TS), = Min -20°C\* to Max 120°C\*\*

Maximum Allowable Pressure (PS), = High Side 27.6 Barg Low Side N/A Barg

\*Based on the refrigerant temperature in the unit off state in the lowest permitted ambient temperature.

\*\*Based on the maximum allowable super-heated refrigerant temperature.

### Pressure System Safety Regulations 2000

Refrigeration assemblies/systems may constitute a Pressure System as defined in the Pressure System Safety Regulations 2000.

### Manual Handling

Some operations when servicing or maintaining the unit may require additional assistance with regard to manual handling. This requirement is down to the discretion of the engineer. Remember do not perform a lift that exceeds your ability.

---

<b>Contents</b>	
<b>Introduction</b>	<b>5</b>
Nomenclature	5
<b>Standard Features</b>	<b>5</b>
<b>Optional Extras</b>	<b>6</b>
<b>Technical Data</b>	<b>7</b>
Mechanical Data	7
Electrical Data	8
Interconnecting Wiring	8
Performance Data	9
Operating Limits	9
Sound Data	10
<b>Installation Data</b>	<b>11</b>
Dimensions - Horizontal	11
Dimensions - Vertical	13
Positioning and Clearance	15
Stacking Units	16
Unit Lifting	16
Pressure Testing	19
Electrical	20
General	21
Operating Limits	22
<b>Commissioning</b>	<b>23</b>
Control Device Adjustment	23
Refrigerant Charging	24
<b>Troubleshooting</b>	<b>25</b>
<b>Maintenance</b>	<b>26</b>

## Introduction

### Nomenclature

#### AIR COOLED CONDENSER UNIT

C / CS	Condenser
11 - 105	Model Size (Expressed as total heat rejection in kW)
HI	Head Pressure Control and Mains Isolator Fitted (C only)
H	Horizontal Air Discharge
V	Vertical Air Discharge
0	(CS only)

Example: C45HI-H  
CS50H-0

### Introduction

This range of air cooled condensers is available in model sizes with heat rejection of 11-105 kW, and has been custom designed for a small footprint, low sound level and slimline, aesthetically pleasing appearance. It is available in either horizontal or vertical air discharge orientation, please specify at order. All units are despatched following extensive leak and pressure testing, and carry a holding charge of inert gas. The unit is designed for the use of R407C. Airedale has a comprehensive range of air cooled direct expansion indoor units available to provide a matched system.

## Standard Features

### Construction

Unit cabinets are manufactured from galvanised sheet steel coated with epoxy baked powder paint to provide a durable finish. Standard unit colour is Light Grey (RAL 7035).

### Condenser

Large surface area coil(s) ideally positioned to optimise airflow and heat transfer, manufactured from refrigeration quality copper tube with mechanically bonded aluminium fins. The copper tube is internally rifled for improved heat transfer. Factory pressure tested to 40Bar. Sweat copper pipe for brazed connection as standard.

### Fan & Motor Assembly

Axial flow fan assembly with low noise sickle type blades and inlet ring. The external rotor motor allows the use of a low power output, single phase, speed controllable motor to power the fan. The motor has inbuilt thermal overload protection and the assembly is supplied complete with a finger guard for protection.

### Refrigeration

Each unit features a filter drier (supplied loose) and a holding charge of inert gas.

### Electrical

All electrical components are rated for all year round outdoor use. All wiring is colour coded and numbered for identification. All units are wired in accordance with current local and European standards.

### Head Pressure Control (C11-45)

Head pressure control is maintained via a factory fitted on/off pressure switch rated to IP54 for outdoor use as standard. This fan switching offers control with ambients down to 0°C, below this temperature variable speed controllers are recommended. Refer to Optional Extras for further information.

### Head Pressure Control (CS50-105)

Head pressure control is maintained via a factory fitted fan speed controller. Modulating head pressure with ambient temperatures down to 0°C

### Main Electrical Isolator

A weatherproof mains isolator is fitted to ensure complete unit isolation of the electrical panel during adjustment and maintenance.

## Optional Extras

### Corrosion Resistant Coated Coils

A corrosion resistant coating can be applied to the aluminium fins for units to be used in aggressive atmospheres.

### Head Pressure Control - Variable Speed (Standard on CS50-105)

Head pressure control is maintained via fan speed modulation. This is a more accurate form of control and will prolong the life of the fan. The controller is rated to IP54 for outdoor use and will operate accurately in ambients down to -20°C.

### Shut Off Valves

Where unit isolation for easier maintenance is required, shut off valves can be supplied loose for on site fitment.

### Coil Guards (CS50-105 only)

Protective mesh guards can be fitted to each of the outer coils to protect against damage.

### Electronically Commutated (EC) Fan Motor (CS50-105 only)

Sickle bladed fan assemblies with integral long bellmouth and fingerproof grille. Incorporates external EC rotor motor technology to provide highly accurate discreet speed control. The fans offer maximum airflow performance while keeping sound levels to a minimum.

Each fan incorporates electronically commutated DC motor control using semi-conductor modules responding to a signal from the Airedale indoor unit. EC motors are DC motors with integrated AC to DC conversion; this gives the flexibility of connecting to AC mains with the efficiency and simple speed control of a DC motor. The EC fan offers significant power reduction in comparison with equivalent AC fan at both full and modulated fan speeds. The inbuilt EC fan control module allows for fan speed modulation from 15-100%, the modulating range of a standard AC fan is typically 40-100% of full fan speed.

Head pressure control is maintained by a modulating fan speed controller fitted to the outdoor unit. The controller is rated to IP54 for outdoor use and will operate accurately in ambient temperatures down to a minimum of -20°C.

## IMPORTANT

All fans are supplied pre-programmed to a head pressure setpoint of 26 barg and proportional band setpoint of 6 barg. For alternative settings, please specify at order.

## Technical Data

### Mechanical Data

	Notes	Units	C11HI	C15HI	C20HI	C25HI	C35HI	C45HI	CS50	CS65	CS80	CS105
<b>Total Heat of Rejection</b>	(1)	kW	11	16.5	20.2	25.6	30.3	46.1	51.8	69.3	84.5	111.3
<b>Dimensions - Horizontal</b>	(2)											
Height		mm	647	647	847	847	1047	1047	1167	1167	1167	1167
Width		mm	679	679	712	712	712	712	1000	1000	1000	1000
Length		mm	1271	1271	1100	1100	1650	1650	2177	2177	3560	3560
<b>Dimensions - Vertical</b>	(2)											
Height		mm	1130	1130	1164	1164	1164	1164	1126	1126	1205	1205
Width		mm	698	698	898	898	1098	1098	1167	1167	1167	1167
Length		mm	1271	1271	1100	1100	1650	1650	2177	2177	3560	3560
<b>Weight</b>												
Machine		kg	53	66	72	79	111	137	167	198	257	309
<b>Condenser</b>			Air Cooled - Rifled Copper Tube/Turbulated Aluminium Fins									
Quantity			1	1	1	1	1	1	1	1	1	1
Total Face Area		m <sup>2</sup>	0.68	0.68	0.80	0.80	1.60	1.60	2.11	2.11	3.63	3.63
Nominal Airflow		m <sup>3</sup> /s	1.13	1.13	2.00	2.25	2.35	4.45	4.80	4.20	7.50	6.60
Discharge			H Horizontal or V Vertical ( <i>Please Specify at Order</i> )									
<b>Fan &amp; Motor</b>			Axial									
Quantity			1	2	1	1	1	2	2	2	3	3
Diameter		mm	400	400	630	630	630	630	630	630	630	630
Maximum Speed		rpm	1430	1430	860	860	860	860	860	860	860	860
<b>Refrigeration</b>			Single Circuit									
Refrigerant Type			R407C									
Holding Charge			Inert Gas									
Coil Volume		l	5.3	5.3	6.1	8.1	15.7	15.7	10.7	21.5	18.3	36.7
Refrigerant Charge	(3)	kg	2.1	2.1	2.3	3.1	6.1	6.1	4.3	8.5	7.3	14.6
<b>Connections</b>												
Liquid Line - Sweat		in	1/2	1/2	5/8	5/8	7/8	7/8	3/4	3/4	7/8	7/8
Discharge Line - Sweat		in	5/8	5/8	7/8	7/8	7/8	7/8	1 1/8	1 1/8	1 3/8	1 3/8

(1) Nominal data based on 35°C ambient and a 50°C mean condensing temperature and using standard fan. All performance data is supplied in accordance with BS EN 14511-1:2013.

(2) Overall dimensions for clearance; refer to *Dimensional & Installation Data* for detail.

(3) For guidance only.

Technical

**Technical Data**

**Electrical Data**

Technical

	Notes	Units	C11HI	C15HI	C20HI	C25HI	C35HI	C45HI	CS50	CS65	CS80	CS105
<b>Unit Data</b>												
	(1)											
Nominal Run Amps		A	0.65	1.3	2.8	2.8	2.8	5.6	5.24	5.24	7.86	7.86
Maximum Start Amps		A	2.6	5.2	5.6	5.6	5.6	11.2	18.34	18.34	27.51	27.51
Recommended Mains Fuse		A	10	10	10	10	10	10	10	10	16	16
Max Mains Cable Incoming		mm <sup>2</sup>	10	10	10	10	10	10	6	6	6	6
Mains Supply			230V / 1Ph + N / 50Hz									
<b>Fan - Per Fan</b>												
Quantity			1	2	1	1	1	2	2	2	3	3
Motor Size		kW	0.18	0.18	0.60	0.60	0.60	0.60	0.60	0.60	0.60	0.60
Full Load Amps		A	0.78	0.78	2.62	2.62	2.62	2.62	2.62	2.62	2.62	2.62
Locked Rotor Amps		A	2.6	2.6	5.6	5.6	5.6	5.6	9.17	9.17	9.17	9.17

OPTIONAL EXTRAS

<b>EC Fans</b>												
Quantity			-	-	-	-	-	-	2	2	3	3
Motor Size		kW	-	-	-	-	-	-	0.71	0.71	0.71	0.71
Full Load Amps		A	-	-	-	-	-	-	3.10	3.10	3.10	3.10
Recommended Mains Fuse		A	-	-	-	-	-	-	10	10	16	16

(1) Nominal data based on 35°C ambient and a 50°C mean condensing temperature and using standard fan.



## Technical Data

### Performance Data

Mean Condensing Temperature °C		Ambient					
		25°C	30°C	35°C	40°C	45°C	48°C
		Output kW	Output kW	Output kW	Output kW	Output kW	Output kW
C11HI	35	6.9	3.24	-	-	-	-
	40	10.81	6.94	3.26	-	-	-
	45	15.05	10.93	6.97	3.27	-	-
	50	19.31	15.11	10.98	6.99	3.28	-
	55	23.66	19.41	15.18	11.02	7.02	4.78
C15HI	35	10.27	4.76	-	-	-	-
	40	16.21	10.37	4.8	-	-	-
	45	22.28	16.36	10.45	4.83	-	-
	50	28.49	22.51	16.49	10.51	4.85	-
	55	34.95	28.81	22.73	16.61	10.57	7.14
C20HI	35	12.52	5.79	-	-	-	-
	40	19.63	12.7	5.86	-	-	-
	45	26.76	19.93	12.84	5.91	-	-
	50	34.7	27.23	20.18	12.96	5.95	-
	55	42.79	35.22	27.65	20.42	13.07	8.82
C25HI	35	15.98	7.41	-	-	-	-
	40	25.35	16.06	7.44	-	-	-
	45	35.17	25.47	16.13	7.47	-	-
	50	45.22	35.31	25.57	16.18	7.49	-
	55	55.5	45.47	35.47	25.66	16.22	10.99
C35HI	35	19.01	8.84	-	-	-	-
	40	29.39	19.02	8.84	-	-	-
	45	40.15	29.54	19.21	8.84	-	-
	50	50.81	40.15	29.66	19.28	8.84	-
	55	61.77	51.08	40.53	29.93	19.34	13.04
C45HI	35	28.88	13.47	-	-	-	-
	40	45.1	29.22	13.6	-	-	-
	45	61.55	45.64	29.47	13.7	-	-
	50	78.93	62.34	46.09	29.69	13.79	-
	55	96.91	79.84	63.05	46.51	29.89	20.28
CS50	35	31.7	13.61	-	-	-	-
	40	50.53	32.16	14.13	-	-	-
	45	69.27	51.15	32.79	14.76	-	-
	50	88.16	70.02	51.84	33.48	15.38	-
	55	107.28	89.08	70.99	52.68	34.29	23
CS65	35	44.3	20.92	-	-	-	-
	40	68.27	44.76	21.43	-	-	-
	45	91.99	68.71	45.27	21.88	-	-
	50	115.85	92.51	69.26	45.9	22.51	-
	55	140.04	116.52	93.21	69.98	46.67	32.35
CS80	35	51.98	22.9	-	-	-	-
	40	82.36	52.84	23.88	-	-	-
	45	112.52	83.36	53.79	24.84	-	-
	50	142.9	113.75	84.5	54.89	25.81	-
	55	173.65	144.39	115.16	85.84	56.19	37.96
CS105	35	71.53	34.06	-	-	-	-
	40	109.82	72.21	34.83	-	-	-
	45	147.74	110.49	73	35.5	-	-
	50	185.9	148.51	111.32	73.95	36.48	-
	55	224.58	186.9	149.56	112.42	75.14	52.26

(1) Output kW refers to the condenser heat of rejection.

### Operating Limits

Standard On/Off Head Pressure Control	
Minimum Ambient Air DB °C	-0
Maximum Ambient Air DB °C	+48

Optional Variable Speed Head Pressure Control	
Minimum Ambient Air DB °C	-20
Maximum Ambient Air DB °C	+48

Technical

**Technical Data**

**Sound Data**

**Measurement of Sound Data**

All sound data quoted has been measured in the third-octave band limited values, using a Real Time Analyser calibrated sound intensity meter in accordance with BS EN ISO9614 Part 1: 2009. All Sound Power Levels quoted are calculated from measured sound intensity according BS EN ISO9614 Part 1: 2009.

**Semi Hemispherical**

Sound Pressure Levels are calculated from sound power using the semi-hemispherical method where the noise source is in junction with 2 boundaries i.e. the floor and 1 wall.

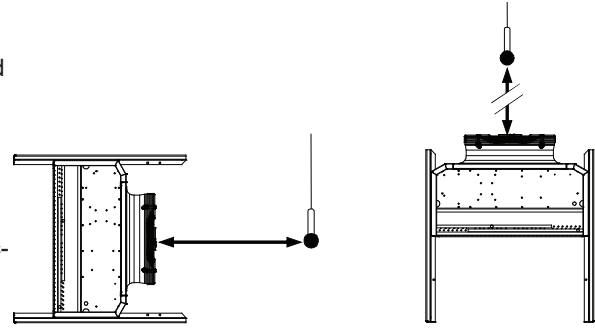

Technical

**Standard Condenser Fan – Horizontal**

Sound Measurement	Overall dB(A)	Frequency (Hz) dB								
		63	125	250	500	1000	2000	4000	8000	
<b>C11HI-H</b> Power dB(A)	67	56	58	63	64	63	61	55	47	
Pressure @ 10m	39	28	30	35	36	35	33	27	19	
<b>C15HI-H</b> Power dB(A)	70	59	61	66	67	66	64	58	50	
Pressure @ 10m	42	31	33	38	39	38	36	30	22	
<b>C20HI-H</b> Power dB(A)	79	78	87	76	73	74	70	62	55	
Pressure @ 10m	51	50	59	48	45	46	42	34	27	
<b>C25HI-H</b> Power dB(A)	79	78	87	76	73	74	70	62	55	
Pressure @ 10m	51	50	59	48	45	46	42	34	27	
<b>C35HI-H</b> Power dB(A)	79	78	87	76	73	74	70	62	55	
Pressure @ 10m	51	50	59	48	45	46	42	34	27	
<b>C45HI-H</b> Power dB(A)	82	81	90	79	76	77	73	65	61	
Pressure @ 10m	54	53	62	51	48	49	45	37	33	
<b>CS50H</b> Power dB(A)	81	84	89	77	77	76	73	66	65	
Pressure @ 10m	53	56	61	49	49	48	45	38	37	
<b>CS65H</b> Power dB(A)	81	84	89	77	77	76	73	66	65	
Pressure @ 10m	53	56	61	49	49	48	45	38	37	
<b>CS80H</b> Power dB(A)	83	80	89	80	77	79	75	68	67	
Pressure @ 10m	55	52	61	52	49	51	47	40	39	
<b>CS105H</b> Power dB(A)	83	80	89	80	77	79	75	68	67	
Pressure @ 10m	55	52	61	52	49	51	47	40	39	

(1) Figures quoted using standard condenser fan(s) running at full speed under normal operating conditions.

**Standard Condenser Fan – Vertical**

Sound Measurement	Overall dB(A)	Frequency (Hz) dB								
		63	125	250	500	1000	2000	4000	8000	
<b>C11HI-V</b> Power dB(A)	68	53	61	63	64	64	62	56	48	
Pressure @ 10m	40	25	33	35	36	36	34	28	20	
<b>C15HI-V</b> Power dB(A)	71	56	64	66	67	67	65	59	51	
Pressure @ 10m	43	28	36	38	39	39	37	31	23	
<b>C20HI-V</b> Power dB(A)	80	75	92	76	73	75	71	63	56	
Pressure @ 10m	52	47	64	48	45	47	43	35	28	
<b>C25HI-V</b> Power dB(A)	80	75	92	76	73	75	71	63	56	
Pressure @ 10m	52	47	64	48	45	47	43	35	28	
<b>C35HI-V</b> Power dB(A)	80	75	92	76	73	75	71	63	56	
Pressure @ 10m	52	47	64	48	45	47	43	35	28	
<b>C45HI-V</b> Power dB(A)	83	78	95	79	76	78	74	66	62	
Pressure @ 10m	55	50	67	51	48	50	46	38	34	
<b>CS50V</b> Power dB(A)	83	81	93	77	77	78	74	68	67	
Pressure @ 10m	55	53	65	49	49	50	46	40	39	
<b>CS65V</b> Power dB(A)	83	81	93	77	77	78	74	68	67	
Pressure @ 10m	55	53	65	49	49	50	46	40	39	
<b>CS80V</b> Power dB(A)	84	76	93	80	78	81	76	70	69	
Pressure @ 10m	56	48	65	52	50	53	48	42	41	
<b>CS105V</b> Power dB(A)	84	76	93	80	78	81	76	70	69	
Pressure @ 10m	56	48	65	52	50	53	48	42	41	

(1) Figures quoted using standard condenser fan(s) running at full speed under normal operating conditions.

## Installation Data

### Dimensions - Horizontal

#### C11HI

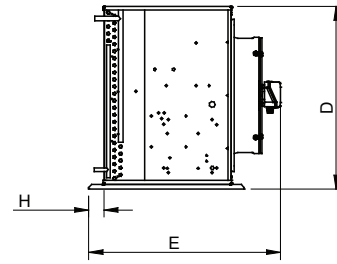
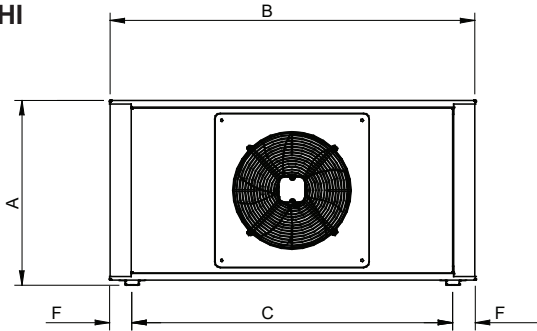

#### C15HI

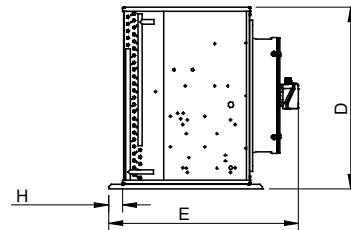
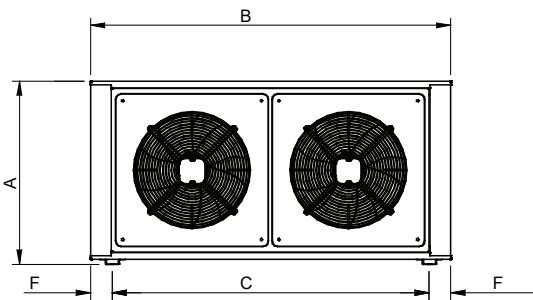

#### C20HI - C25HI

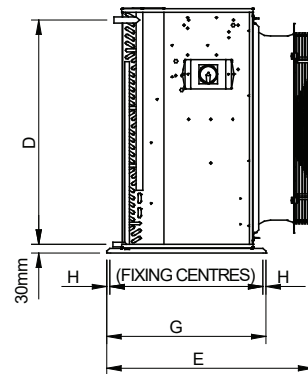
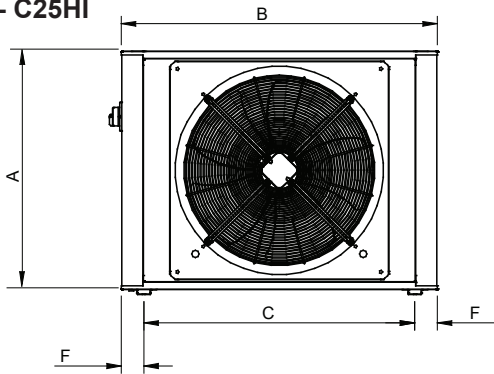

#### C35HI

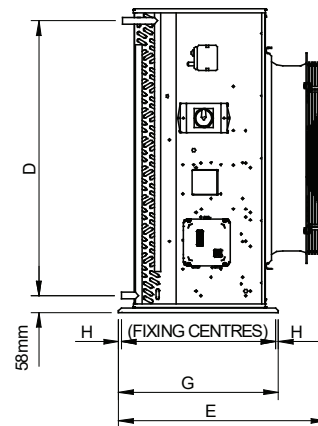
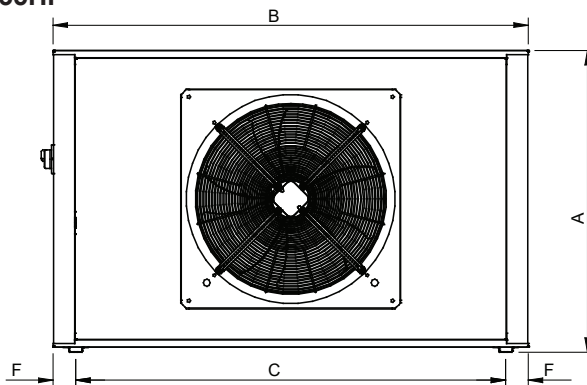

	UNITS	A	B	C	D	E	F	G	H	INLET CONNECTION	OUTLET CONNECTION
C11HI	mm	647	1271	1119	647	679	78	-	54	5/8"	1/2"
C15HI	mm	647	1271	1119	647	679	76	-	50	5/8"	1/2"
C20HI-C25HI	mm	847	1100	994	778	712	78	550	10	7/8"	5/8"
C35HI	mm	1047	1650	1494	948	712	78	550	10	7/8"	7/8"

Installation

Installation Data

Dimensions - Horizontal

C45HI

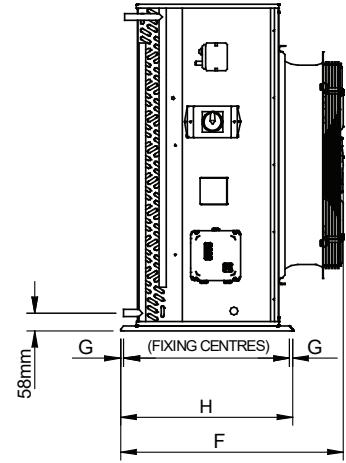
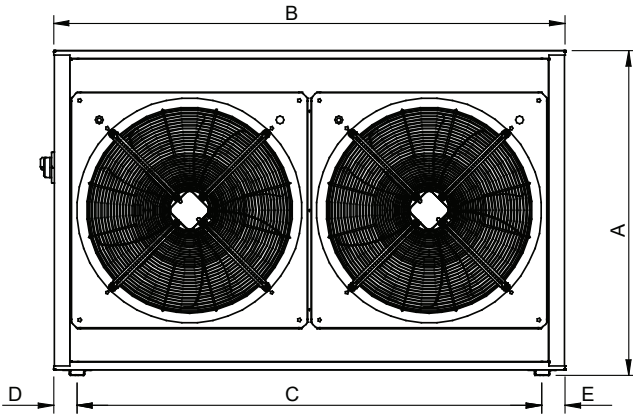

Installation

CS50 - CS65

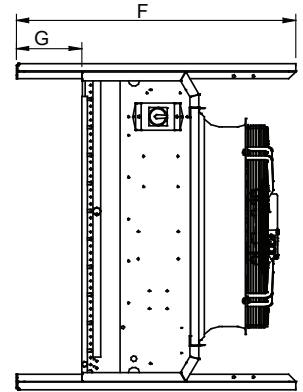
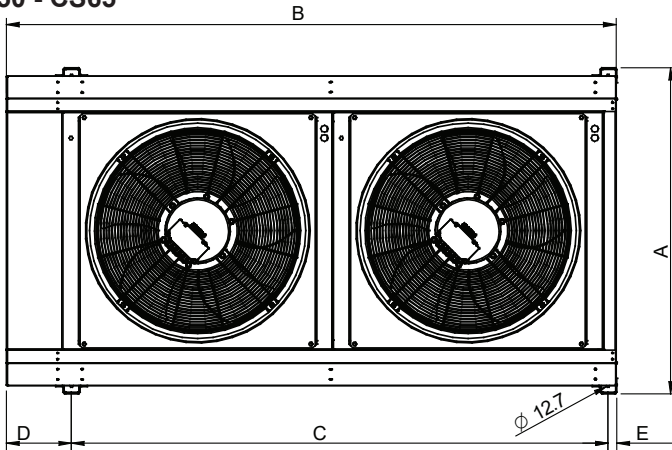

CS80 - CS105

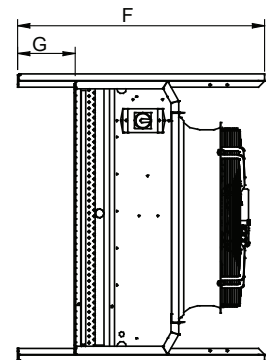
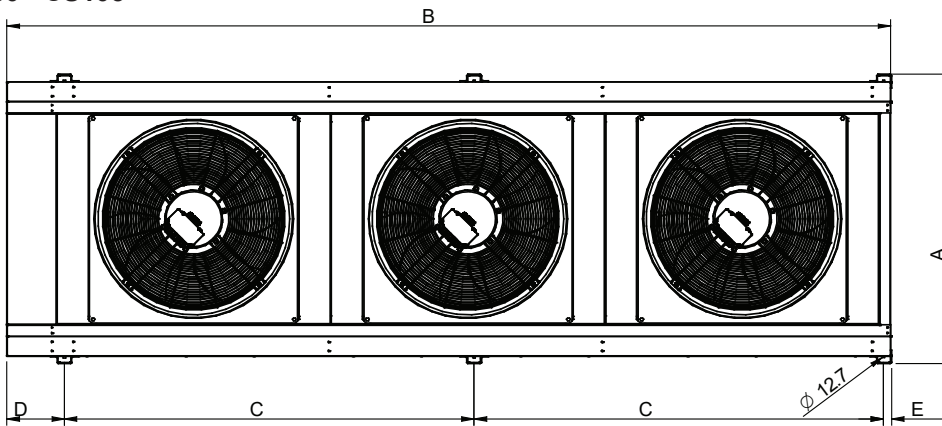

	UNITS	A	B	C	D	E	F	G	H	INLET CONNECTION	OUTLET CONNECTION
C45HI	mm	1047	1650	1500	75	75	712	10	550	7/8"	7/8"
CS50-65	mm	1167	2177	1917	232	32	1000	234	-	1-1/8"	3/4"
CS80-105	mm	1167	3560	1650	232	32	1000	234	-	1-3/8"	7/8"

## Installation Data

### Dimensions - Vertical

C11HI

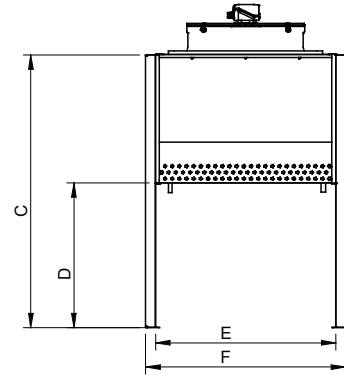
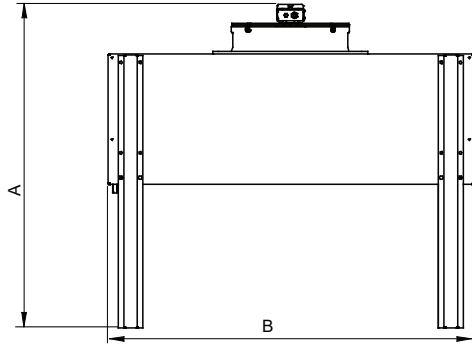

C15HI

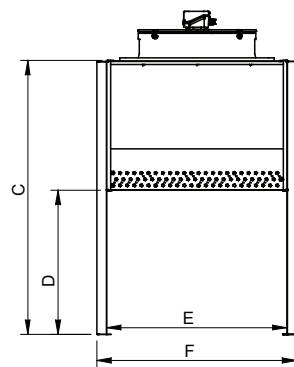
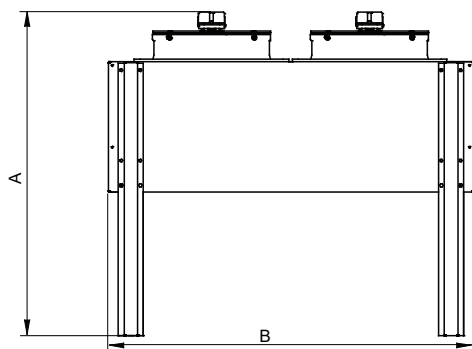

C20HI - C25HI

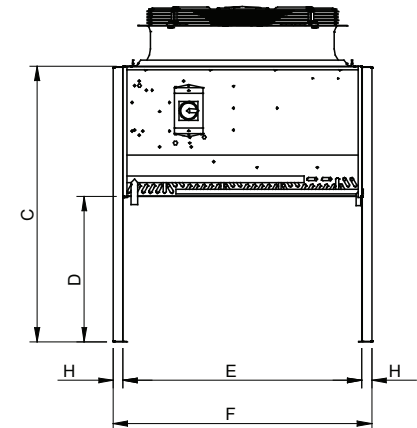
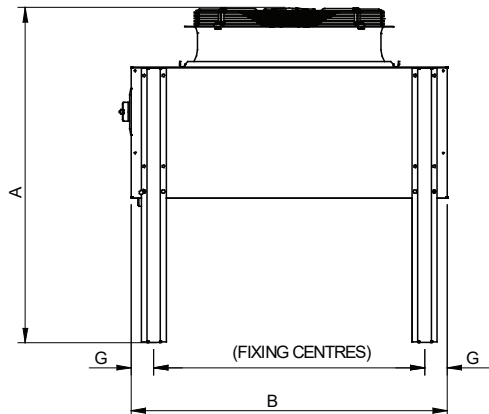

C35HI

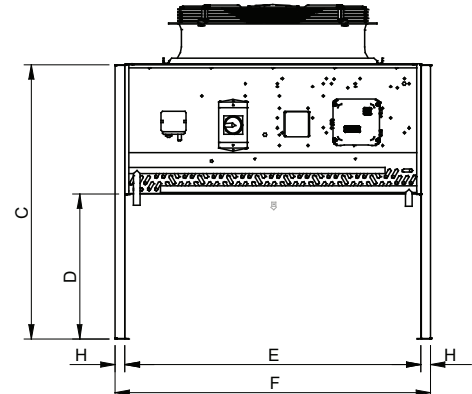
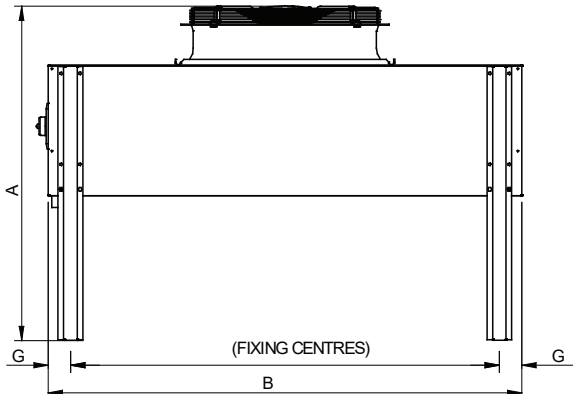

	UNITS	A	B	C	D	E	F	G	H	INLET CONNECTION	OUTLET CONNECTION
C11HI	mm	1131	1271	964	507	630	698	-	-	5/8"	1/2"
C15HI	mm	1131	1271	956	505	630	698	-	-	5/8"	1/2"
C20HI-C25HI	mm	1164	1100	967	505	830	898	78	34	7/8"	5/8"
C35HI	mm	1164	1650	954	505	1030	1098	78	34	7/8"	7/8"

Installation

Installation Data

Dimensions - Vertical  
C45HI

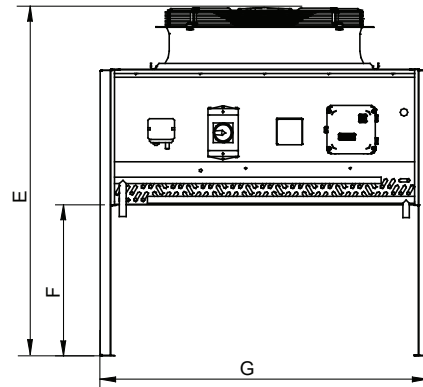
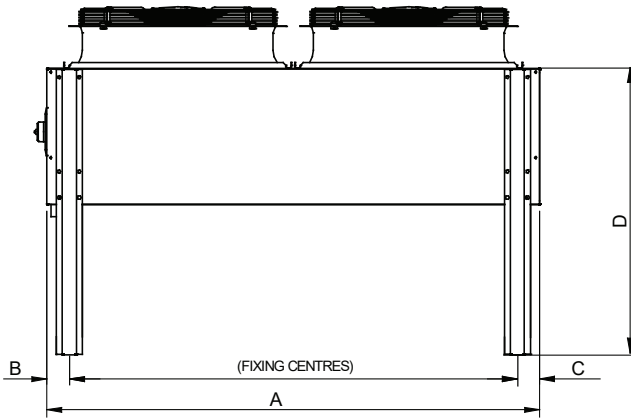

Installation

CS50 - CS65

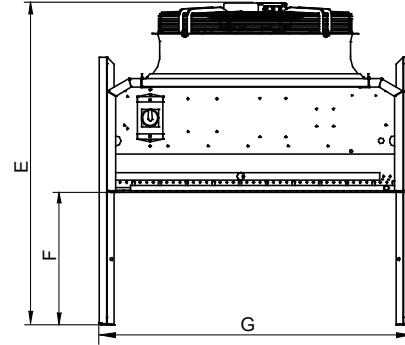
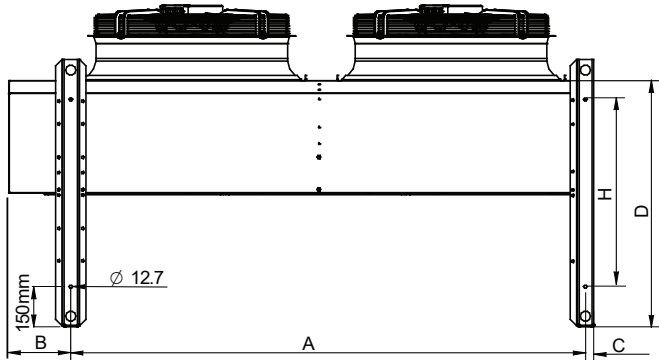

CS80 - CS105

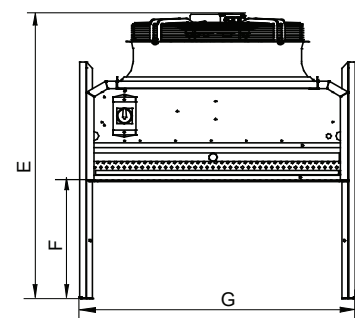
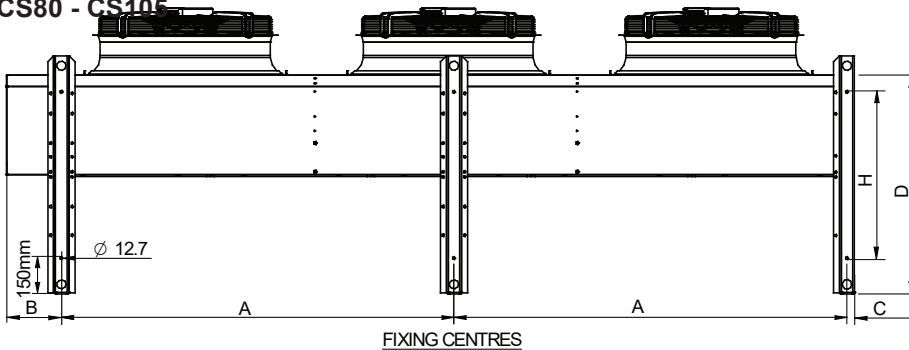

	UNITS	A	B	C	D	E	F	G	H	INLET CONNECTION	OUTLET CONNECTION
C45HI	mm	1650	75	75	954	1164	505	1098	-	7/8"	7/8"
CS50-65	mm	1918	232	32	920	1205	500	1167	700	1-1/8"	3/4"
CS80-105	mm	1650	232	32	920	1205	500	1167	700	1-3/8"	7/8"

## Installation Data

### Positioning and Clearance

- Unit must be positioned on an even base to ensure correct operation.
- Observe airflow and maintenance clearances.
- Where multiple units are installed, due care should be taken to avoid the discharge air from each unit adversely affecting other units in the vicinity.
- When mounting the units adjacent to a wall or other vertical surface, the condenser should be positioned with the coil side facing the wall.
- Check all the services are present and accessible.

### Mounting

Fix the condenser down using the appropriate bolt holes in the unit fixing legs .

### Horizontal Airflow Configuration

Clearance is required as below. Considerations must be taken into account ensuring air is not recirculated. Recirculated air could cause the unit to malfunction.

- Avoid where possible siting the unit where wind and air recirculation may interfere with the fan operation.

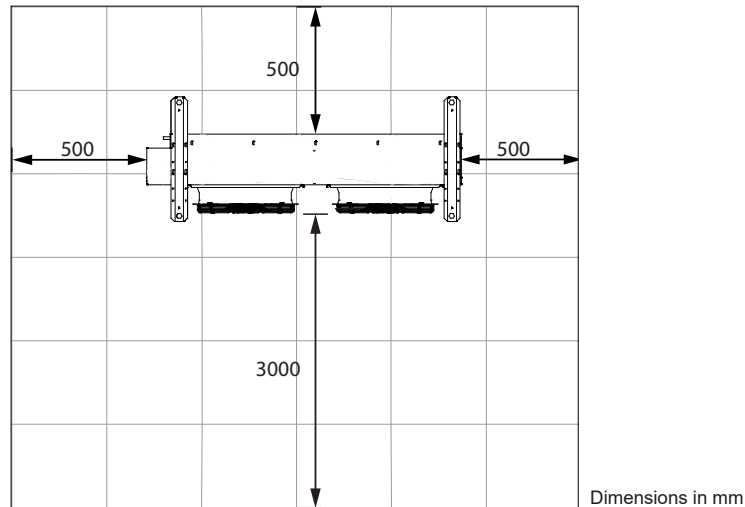

### Vertical Airflow Configuration

Clearance is required as below. Consideration must be given to ensure air is not recirculated by overhead obstructions such as pipework or ducting. Recirculating air could cause the unit to malfunction.

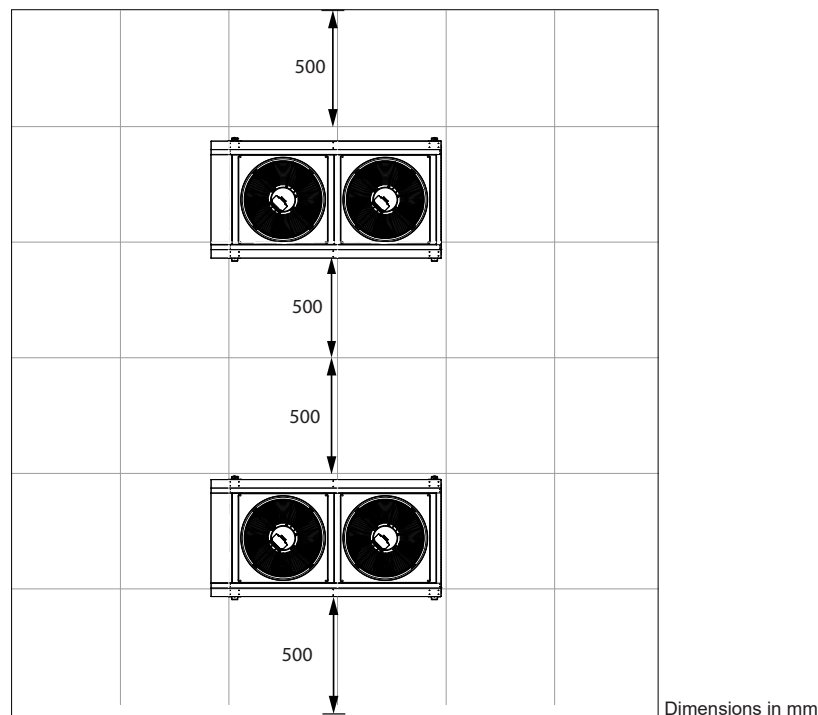

**IMPORTANT** ⚠ If the unit is installed in particularly windy locations, the provision of wind breaks may be required. For such applications a vertical discharge unit is recommended or where horizontal airflow could be obstructed.

Installation

**Installation Data**

**Stacking Units**

Positioning condensers stacked on top of each other can cause the bottom unit to be starved of air. It is therefore required that additional clearance is allowed.

Single unit clearance is 500mm, stacked units clearance is 1500mm.

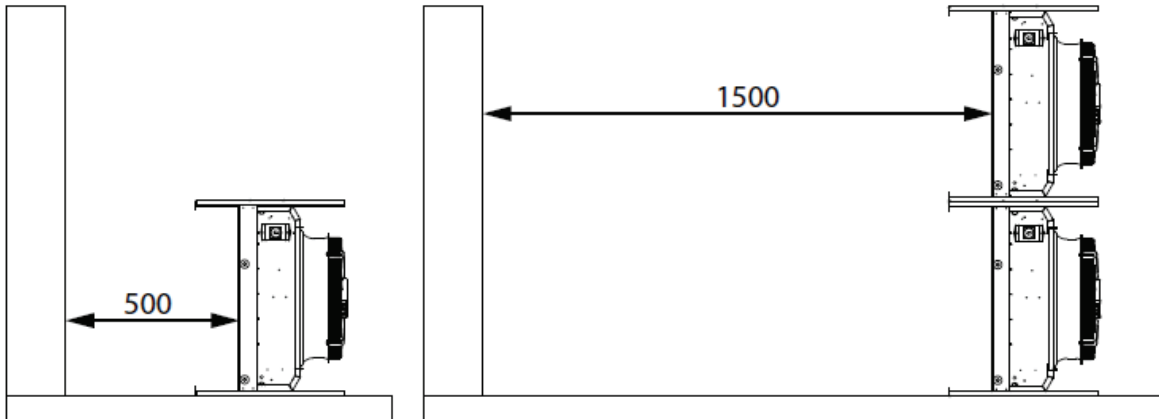

Installation

**Unit Lifting**

**General**

- Employ lifting specialists
- Local codes and regulations relating to the lifting of this type of equipment should be observed
- Each chain/sling must be capable of lifting the whole unit
- Lift the unit slowly and evenly

**IMPORTANT**

Only use lifting points provided. Do not lift from the pipework connections as this may damage the unit.

- Do not use 1 chain between 2 lifting points to avoid load shift.
- Ensure that chains/slugs DO NOT crush the casework, coil or fan assemblies.
- If the unit is dropped it should immediately be checked for damage and reported to Airedale.
- Airedale will accept no responsibility for mishandling during the positioning of the equipment.

<p><b>CAUTION</b> ⚠</p>	<p>Check the unit is as ordered, discrepancies or transit damage should be reported to Airedale immediately.</p> <p>Care should be taken to ensure the unit does not sustain damage before it is lifted into final position.</p>
-------------------------	--

**Horizontal Air Discharge**

Use lifting eyes attached to individual slings/chains (supplied by others) and attach 2 to every top leg using the holes provided as illustrated. Maximum of 6 slings/chains.

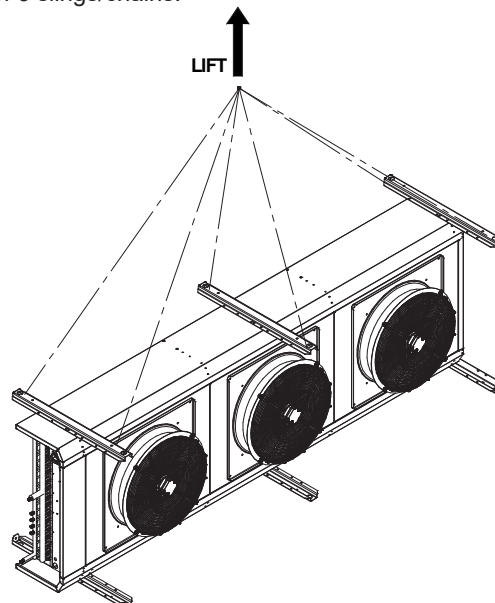



## Installation Data

### Vertical Air Discharge

Use lifting eyes attached to individual slings/chains (supplied by others) and attach 1 to the top of every leg using the holes provided as illustrated. Maximum of 6 slings/chains.

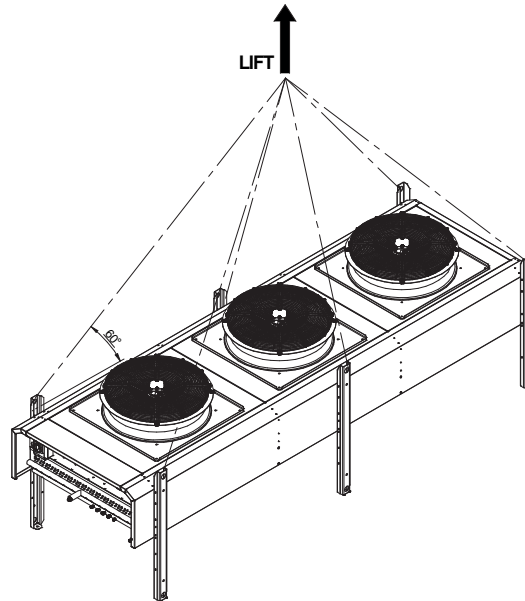

Installation

### Re-Orientation To Vertical Discharge - CS Units Only

1. Remove the fixings securing the unit to the pallet.
2. In line with horizontal discharge lifting instructions, lift the unit sufficiently to gain access to the lower leg fixings.
3. Reposition and secure the lower 2 legs to the corner of the unit using the fixings and hole positions provided to both faces. Note, model sizes CR80 & CR105 have an additional mid support leg, this should also be adjusted and secured.
4. Lower and rest the unit down to floor and reposition and secure the upper legs as described in Step 3.
5. In line with vertical discharge lifting instructions lift the unit slowly into vertical orientation.

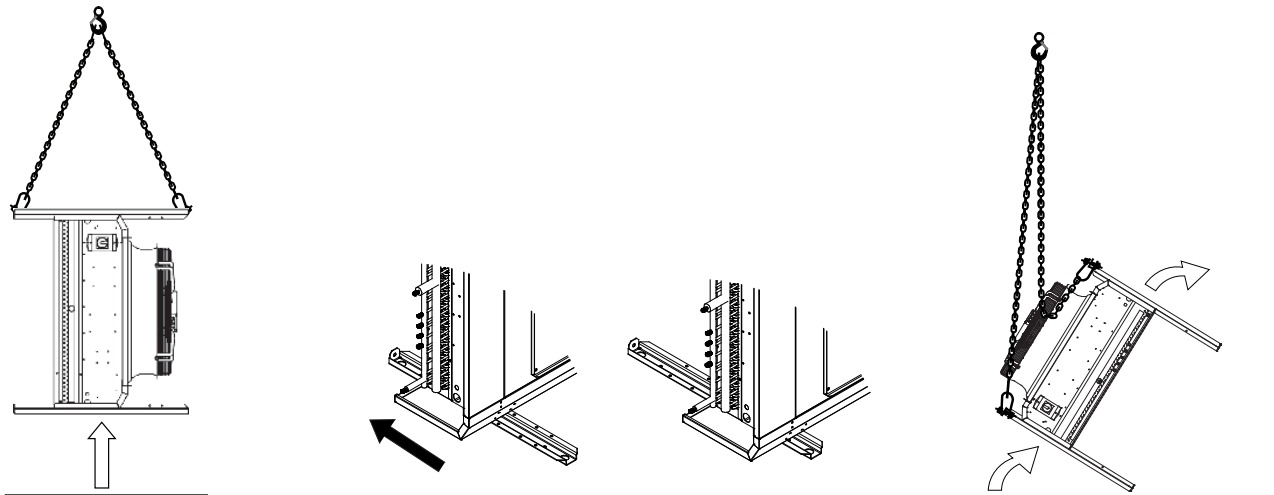

**CAUTION** ⚠

It is strictly prohibited to use the connections, which are delicate parts of the Coil, as anchoring points when lifting or handling the unit. This would cause serious damage to the Coil and serious risks for the safety of persons and goods.

**Installation Data**

**Holding Charge**

The units are shipped with a holding charge of inert gas to guard against contamination or moisture during shipping and storage. The charge should be checked to indicate if leaks are present prior to evacuation. If the charge appears to be either partially or totally lost, then the unit should be carefully checked for signs of physical damage.

**Pipework Installation - Good Practices**

- Installation and brazing of interconnecting pipework should be carried out by qualified personnel only.
- Use straight line routes wherever possible.
- When cutting tubes to length, ensure that the ends are cut square using dedicated copper tube cutters.
- Remove burrs to the ends of the copper tube, holding the tube downward to avoid allowing dirt to contaminate the tube.
- Ensure the mating surfaced to be brazed are cleaned and free of debris.
- To prevent oxide particle built up, an inert gas (e.g. nitrogen) should flow freely through the piping system during the brazing operation at an appropriate flow rate, following and initial purge of all air from the pipe being brazed.
- The coil must be adequately protected from heat when brazing work is carried out. Do not swage the coil. The pipework must only be swaged to avoid additional stress and heat on the coil. Brazing must be done away from the coil. An appropriate thermos-insulating gel is recommended to protect the aluminium coil from heat. Failure to do so may damage the coil and invalidate warranty.
- Refrigerant lines should be insulated in areas of high/low temperature or when exposed to direct sunlight.
- When insulating refrigerant lines, cut approximately 30 - 50cm longer than the distance between the units to ensure the insulation goes right up to the unit. Leave connections uncovered for leak testing.
- When clamping, avoid any contact between the discharge line and the liquid line.

**Pipe Supports**

**IMPORTANT** ⚠ Weight of pipework must not be supported by the unit. Three planes of movement must be allowed between the coil the first pipe clamp. If this is not possible a vibration eliminator (anaconda) must be fitted. The following table identifies the maximum distance between system pipe supports on vertical and horizontal pipe runs. All pipework should be clamped prior to insulation being applied.

Pipe O/D (inches)	Support distance (m)
3/8 - 7/8	1.0
1 1/8 - 2 1/8	2.0

**Pipe Lengths**

**Discharge Line**

Maximum pressure loss for discharge pipework 42 kPa. Minimum velocity for discharge risers 5 m/s, to ensure good oil return.

**Liquid Line:**

Maximum pressure loss for liquid line pipework 21 kPa. Minimum velocity for liquid line 0.5 m/s, to ensure good oil return.

**Oil Traps**

For long vertical rises in discharge lines, it is essential that oil traps are located every 4m to ensure proper oil movement/ entrapment. In addition there should be an oil trap at the exit of the air handling unit before a vertical riser is applied (refer to example below).

**Condenser above indoor unit**

**Condenser below indoor unit**

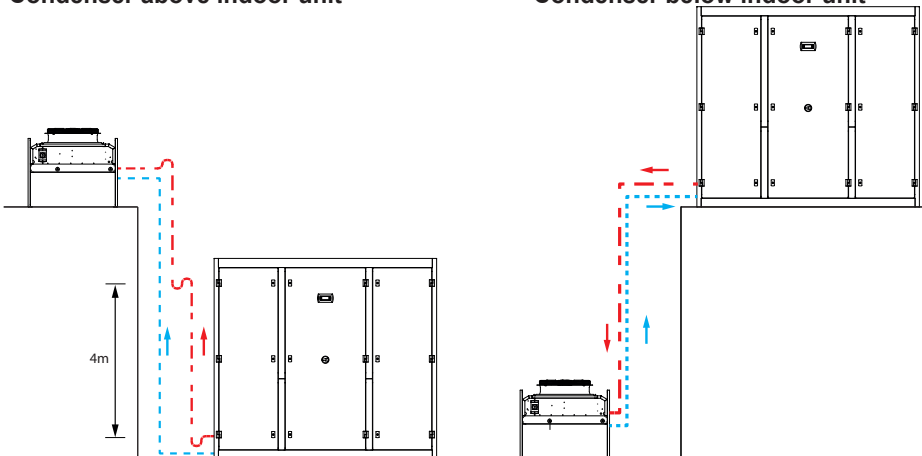

**IMPORTANT** ⚠ It is the responsibility of the installing contractor/site engineer to check the pipe size/refrigerant charge is correct for each system installation and application. Split systems may require additional oil which should be added to the low pressure side of each compressor. Design should be in accordance with accepted refrigeration practice to ensure good oil return to the compressor(s) under all normal operating conditions. REMEMBER excessive pressure loss in interconnecting pipework will impair system performance; this should be factored in during the design of the system and where necessary oil traps employed.

## Installation Data

### Pressure Testing

In accordance with PED 2014/68/EC, a strength test should be carried out in order to ensure that all interconnecting joints, pipework and components are sufficiently strong to cater for maximum permissible operating pressures.

#### CAUTION ⚠

Once installation is completed, the high pressure side of the system should be strength tested with dry nitrogen. To comply with the PED directive, the unit is factory pressure tested and recorded on the test certificate provided.

**SPLIT SYSTEMS:** Ensure additional in line system components will withstand the intended system PED recommendation test pressure. If not, we recommend isolation where possible, eg in-line HP/LP switches, pressure transducer(s) and compressor(s).

Pressure testing can be dangerous if not properly conducted; personnel undertaking pressure testing **MUST** be technically competent and suitably qualified.

- Record the pressure over a minimum of 60 minutes to detect major leaks (a 24 hour period should preferably be allowed), on the commissioning sheet provided.
- If a reduction in pressure is detected, trace the leak and repair before conducting a further pressure test and charging.

### Evacuation

Evacuation for systems operating on R407C refrigerant should be carried out as follows: (for other refrigerants refer to Airedale for advice).

- All system valves (i.e. liquid line solenoids, EEVs, shut off valves etc) need to be open to allow evacuation.
- Use a high vacuum pump and connect to the high and low pressure sides of the system via a gauge manifold fitted with compound gauges, a high vacuum gauge should be fitted to the system at the furthest point from the vacuum pump.
- The system should be evacuated to 0.5 Torr and if achieved no further evacuation steps are required.
- Triple evacuation should be used to ensure that all contaminants are removed if initially 0.5 Torr could not be achieved.
- Operate the vacuum pump until a pressure of 1.5 Torr (200 Pa) absolute pressure is reached, then stop the vacuum pump to break the vacuum using oxygen free Nitrogen until the pressure rises above zero. The above operation should be repeated a second time.
- The system should then be evacuated a third time but this time to 0.5 Torr absolute pressure.

**Installation Data**

**Electrical**

<b>CAUTION</b> ⚠	The following information is for general guidance; refer to the certified drawings provided for installation.
	ALL work <b>MUST</b> be carried out by technically trained competent personnel.
	The equipment contains live electrical and moving parts, <b>ISOLATE</b> prior to maintenance or repair work.

**General**

- Once the refrigeration pipework is complete the electrical supply can be connected as per the wiring diagram supplied with each unit.
- A fused and isolated electrical supply of the appropriate rating should be installed.
- As standard the equipment is designed for 230V, 1 Phase, 50Hz to all relevant IEE regulations, British standards and IEC requirements.
- All mains and interconnecting wiring should be carried out to National and Local codes.
- Wires should be capable of carrying the maximum load current under non-fault conditions at the stipulated voltage.
- Avoid large voltage drops on cable runs, particularly low voltage wiring.
- Each unit requires an independently fused and isolated power supply.

**Interconnecting Wiring**

<b>C11 - 45</b>	L1	○
	N	○
	E	○

Mains Incoming 230V / 1Ph + N / 50Hz

<b>CS50 - 105</b>	L1	○
	N	○
	PE	○

Mains Incoming 230V / 1Ph + N / 50Hz

<b>IMPORTANT</b> ⚠	This system has been designed to be connected to a TN type distribution system. For alternate distribution type systems, contact Airedale.
--------------------	--

Installation

## Maintenance

<b>CAUTION</b> ⚠	ALL work MUST be carried out by technically trained competent personnel.
------------------	--

The equipment contains live electrical and moving parts, ISOLATE prior to maintenance or repair work.

<b>IMPORTANT</b> ⚠	Ensure relevant F-Gas Regulation checks are carried out at the appropriate period.
--------------------	--

### GENERAL MAINTENANCE

The maintenance schedule indicates the time period between maintenance operations.

#### 3 MONTHS

At every service visit the following checks should be carried out:

##### Fan & Motor Assembly

- 1 Examine the fan and motor assemblies for lateral and end play in the bearings.
- 2 Ensure that no water is entering the motor via the electrical gland plate.
- 3 Check fan blades for damage and corrosion.

##### Refrigeration Circuits

- 1 Visually examine pipework and components for damage, wear and tear and oil patches, the latter being indicative of a system leak.
- 2 Ensure the fan head pressure controller is controlling the head pressure at the required setting as indicated on the commissioning sheets provided.

The gauges can then be removed from the system. Do not forget to replace the security caps on the Schrader valves.

##### Condenser Coil

Clean the condenser coil with pressurised air, following the same direction as the fins. Ensure the pressure does not exceed 10 bar and that a minimum distance of 300mm is maintained. Take care not to damage the fins and comb out if they have been knocked from their correct alignment. Ensure that any cleaning solution has a PH value between 7 and 8.2.

<b>CAUTION</b> ⚠	Do not use steam or harsh chemicals for cleaning condenser coils as this may damage the coils or cause excessive internal pressures.
------------------	--

##### Electrical

- 1 Check all electrical connections for signs of overheating or arcing.
- 2 Check all cables for signs of chafing or physical damage.

##### Cabinet

- 1 Clean the cabinets using a mild detergent.
- 2 Treat any paint damage or rust as necessary.

#### 12 MONTHS

As per 3 months plus the following:

- 1 Check all electrical connections for security.
- 2 Check all refrigeration connections with a leak detector.

## After Sales Warranty

All Airedale products or parts (non consumable) supplied for installation within the UK mainland and commissioned by an Airedale engineer, carry a full Parts & Labour warranty for a period of 12 months from the date of commissioning or 18 months from the date of despatch, whichever is the sooner.

Parts or Equipment supplied by Airedale for installation within the UK or for Export that are properly commissioned in accordance with Airedale standards and specification, not commissioned by an Airedale engineer; carry a 12 month warranty on non consumable Parts only from the date of commissioning or 18 months from the date of despatch, whichever is the sooner.

Parts or equipment installed or commissioned not to acceptable Airedale standards or specification invalidate all warranty.

### Warranty is only valid in the event that

In the period between delivery and commissioning the equipment:

- is properly protected & serviced as per the Airedale installation & maintenance manual provided
- where applicable the glycol content is maintained to the correct level.

In the event of a problem being reported and once warranty is confirmed\* as valid under the given installation and operating conditions, the Company will provide the appropriate warranty coverage (as detailed above) attributable to the rectification of any affected Airedale equipment supplied (excluding costs for any specialist access or lifting equipment that must be ordered by the customer).

\*Once warranty is confirmed, maintenance must be continued to validate the warranty period.

Any spare part supplied by Airedale under warranty shall be warranted for the unexpired period of the warranty or 3 months from delivery, whichever period is the longer. To be read in conjunction with the Airedale Conditions of Sale - Warranty and Warranty Procedure, available upon request.

### Procedure

When a component part fails, a replacement part should be obtained through our Spares department. If the part is considered to be under warranty, the following details are required to process this requirement. Full description of part required, including Airedale's part number, if known. The original equipment serial number. An appropriate purchase order number.

A spares order will be raised under our warranty system and the replacement part will be despatched, usually within 24 hours should they be in stock. When replaced, the faulty part must be returned to Airedale with a suitably completed and securely attached "Faulty Component Return" (FCR) tag. FCR tags are available from Airedale and supplied with each Warranty order.

On receipt of the faulty part, suitably tagged, Airedale will pass to its Warranty department, where it will be fully inspected and tested in order to identify the reason for failure, identifying at the same time whether warranty is justified or not.

On completion of the investigation of the returned part, a full "Report on Goods Returned" will be issued. On occasion the release of this complete report may be delayed as component manufacturers become involved in the investigation. When warranty is allowed, a credit against the Warranty invoice will be raised. Should warranty be refused the Warranty invoice becomes payable on normal terms.

### Exclusions

Warranty may be refused for the following reasons.

- Misapplication of product or component
- Incorrect site installation
- Incomplete commissioning documentation
- Inadequate site installation
- Inadequate site maintenance
- Damage caused by mishandling
- Replaced part being returned damaged without explanation
- Unnecessary delays incurred in return of defective component

### Returns analysis

All faulty components returned under warranty are analysed on a monthly basis as a means of verifying component and product reliability as well as supplier performance. It is important that all component failures are reported correctly.



Head Office  
Airedale International Air Conditioning Ltd  
Leeds Road  
Rawdon  
Leeds LS19 6JY

Tel: +44 (0) 113 2391000  
Fax: +44 (0) 113 2507219

E-mail [connect@airedale.com](mailto:connect@airedale.com)  
Web: [www.airedale.com](http://www.airedale.com)